

C. S. OSBORNE & CO.

ESTABLISHED 1826

Factory and Main Office

125 Jersey Street

Harrison, N.J. 07029 - U.S.A.

Fax #(973) 484-3621

E-Mail address: cso@csosborne.com

Web site address: www.csosborne.com

TOOLS FOR UPHOLSTERERS, AUTO TRIMMERS AWNING AND CANVAS WORKERS



Since 1826, the Osborne family has dedicated itself to providing the very finest tools. Ably assisted by employees who average over ten years of service to the company, the seventh generation of the Osborne family still manages the firm and continues the tradition requiring strict adherence to the highest standards of quality and service. This dedication continues to put the best possible tools in the hands of the professional.

OUR PRODUCTS

Osborne tools are sold through distributors.

All orders are accepted on the basis of price in effect at time of shipment.

GUARANTEE

We will replace, free of charge, any tool which may prove unsatisfactory in performance if sent for inspection, transportation prepaid. Tools which are known to have given reasonable service, or have been misused, or damaged, will not be considered defective.

All orders are accepted on the basis of price in effect at time of shipment

INDEX

Arch Punches	61	Hammer, Claw Tack	7	Punch, Solid	58
Awl, All Purpose,Bent	45	Hog Rings	50	Punch, Ventilator	41
Awl, Automatic	46	Hog Ring, Pliers	48-49	Regulator, Upholsterer's	73
Awl, Badminton	45	Hook	17	Regulator, w/Plastic Handle	73
Awl, Saddler's	47	Klinch-It Tool	20	Release, Moulding Key	51
Awl, Scratch	45	Klinch-It Fasteners	20	Remover, Clip & Dorr Handle	51
Awl, Sewing	47	Knife, Bevel Point	44	Remover, Trim Pad	51
Awl, Stabing	47	Knife, Combination	43	Rivets	68
Awl, Tennis	45	Knife Hawkbill	43	Rivets/ Setters	68
Basket Weaving Tools	40	Knife, Skiving	43	Roller, Vinyl, Carpet Veneer	52
Bazooka, Filler	24	Knife, Sharp & Square Point	44	Rule, Aluminum	21
Bag, Rat	24	Knife, Windshield	51	Rule, Wood	21
Belt Punches	64	Lacing Plier	52	Sail, Palm	72
Bone Folders	42	Lifter	11	Sewing Palm	72
Button, Backs	31	Magnetic Nail & Tack Placer	6	Sharpening Stone	43
Button, Combos	36-37	Mallet, Hickory	60	Shears, Wiss	54,57
Button, Plastic Domed	33	Mallet, Rawhide	59	Shears, Ergo-Cut	53
Button, Machines	28-35	Mallet, Rubber	60	Sheath, Safety	44
Button & Foam Cutters	22	Nails, Decorative	25	Shells, Button	31
Button Dies	29	Nail, Dent & No Dent	33	Skife, Knife-Blades	43
Carboard Disk	34	Nail, Spacer	25	Snaps	70,71
Chalk, Marking	41	Nail, Threaded	33	Snap Set, Kits	69
Chisel, Caning	40	Nail, Plier	25	Snap Set	69
Chisel, Bent Ripping	12	Needle Chart	74	Snap Setter only	69
Chisel Straight	12	Needle, Bent/Straight Pack	77	Snaps Rings, Plastic	33
Chisel, Wood	11	Needle, Bolster	77	Snips	57
Claps, Tufting	38	Needle, Caning	40	Socket Remover	23
Claw, Tools	9-10	Needle, Carpet	79	Spring Bender	19
Claw, Tack	11	Needle, Chenille	78	Spring End Former	19
Clip, Thread	56	Needle, Curved	76	Spring, Puller Hook	17
Clips, 3 Prong	18	Needle, Flocking	77	Spring Spreader	20
Clips, EK	18	Needle, Glover's	78	Staple Knocker	9
Clips, Lined BW	18	Needle, Harness	78	Staple Lifters	9,10
Combination Tool	12	Needle, Kits	75	Staple Removers	9
Collets	34	Needle, Lampshade Rd. Pt.	76	Stretcher, Level Spring	17
Connectors, Spring & Wire	18	Needle, Loop	39	Stretcher, Blind Stitching Seam	23
Cutter, Button	22,29	Needle, Mattress	76	Stuffing Iron, Stuffing Rod	24
Cutter Quick Clip	56	Needle, Sewing/ Stringing	78	SuperHook, Nylon	34
Cutter, Side	14	Needle, Sailmaker's	77	Tack Strip	18
Cutting Nippers	13	Needle, Smyrna	78	Thimbles	72
Cutting Pad	59	Needle, Straight	77	T-Nuts	19
Dies, Snap	30	Needle, Tapestry	78	Trim Pad Remover	51
Dies, Ventilator	30,41	Needle, Tufting	38	Tucking Tool	46
Durable Snap Setter	69	Pin Remover & Resetter	23	Tufter, Mattress Button	38
Eyelet Setter	68	Pincers, Ripping	13	Tufter, Prong Button	39
Foam Cutter, U-Cut	23	Pinch Dogs	21	Tufting Tool, T-Handle	39
Glue Sticks	52	Pins, Upholstery, Tist, T, Push	73	Tufting Twine, Nylon	39
Grommet Die, Midget	66	Piping Tins	23	Upholstery Kits	26,27
Grommet Hole Cutter	65	Pliers, BW Clip	18	Ventilators	41
Grommet and Washers	65	Pliers, Canvas	16	Ventilator, Hand Setter	41
Grommet Inserting Die	65	Pliers, Duckbill	14	Webbing Stretcher, Metal	19
Grommet, Kits	67	Polywasher for superhook	34	Webbing Stretchers	15
Haft, Palm Awl	47	Prong	32	Wire Cutter, Heavy Duty	20
Haft, Peg Awl	47	Prongs Washers	32	Wire Eyes	31
Haft, Sewing	47	Punch Aligning	58		
Haft, Shoe Awl	47	Punch, Arch. Sets	62		
Hammer Glazier	8	Punch, Belt-Sets	62,64		
Hammer, Magnetic Bronze	5	Punch, Center	58		
Hammer, Magnetic Forged Steel	5,6	Punch, Drive	64		
Hammer, Magnetic Tack	6	Punch, Mini-Set	63		
Hammer, Ripping	6	Punch, Prick	58		
Hammer, Riveting	8	Punch, Revolving	58		
Hammer, Split Head	59	Punch, Self-Centering, Sets	63		
Hammer, Nylon Tip	5				

OSBORNE



TOOLS

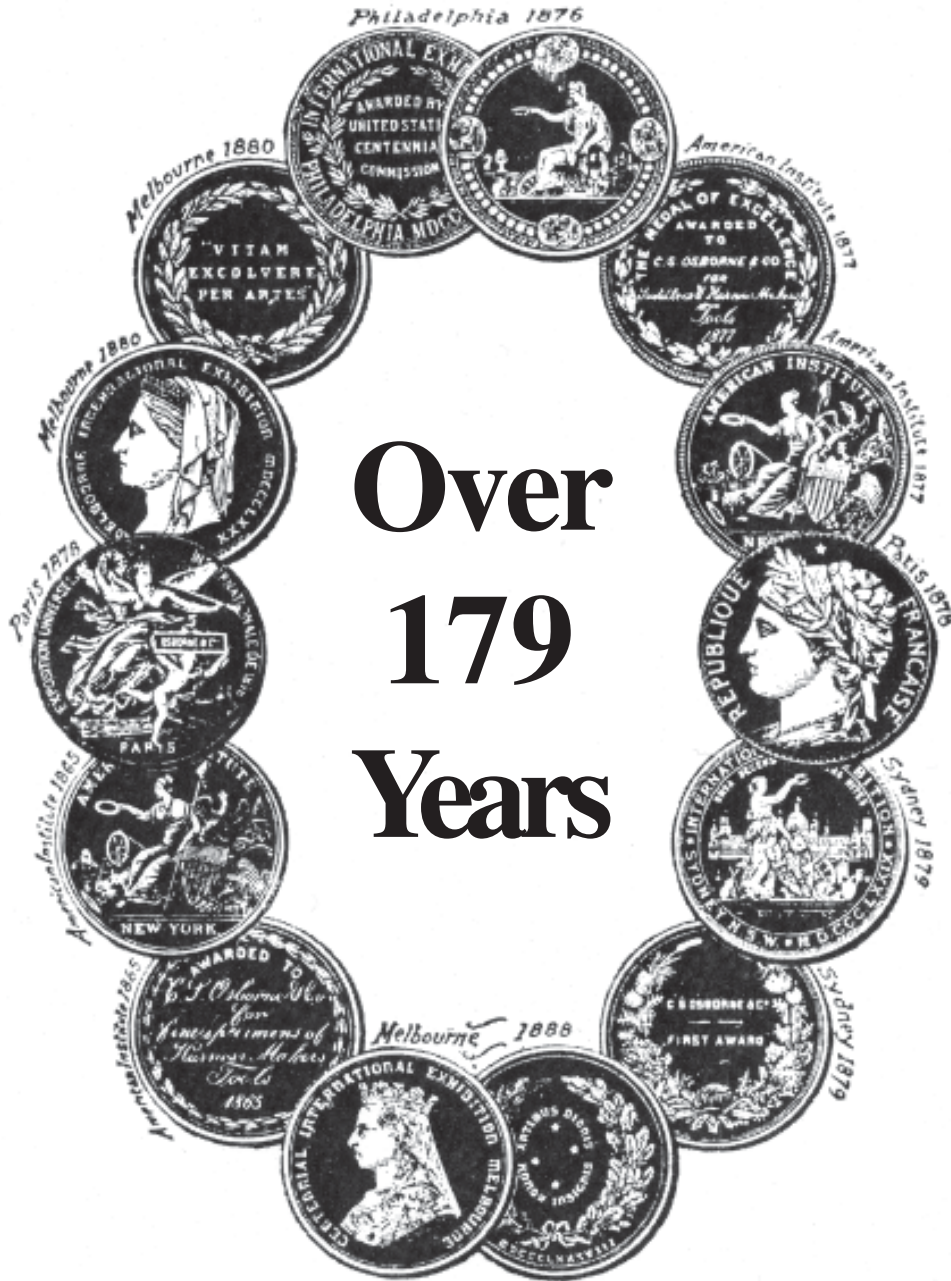

**THE GOLD MEDALS SHOWN ABOVE SYMBOLIZE THE PRIDE
TAKEN IN OUR TOOLS BY SEVEN GENERATIONS OF
OSBORNES**



Osborne magnetic hammers will give long service if properly used and stored. The magnetic end must be used only for setting a tack in place. The striking end is for driving tacks home. The magnetic head should never be left in contact with other steel objects. Should one of our hammers lose its magnetism, we will recharge free or charge it if sent prepaid to the factory.

7 OZ. HEAD BRONZE MAGNETIC HAMMER



Osborne No. 33

Solid head of bright bronze. Steel tipped at one end for permanent magnet and at the other for hammering. Balanced design, shellacked hardwood handle.

Length of head (inches)	Weight of head (oz)	Magnetic face (inches)	Large face (inches)	Weight ea (oz)	UPC No.
5 1/2	7	1/4	7/16	11	56042

9 OZ. HEAD BRONZE MAGNETIC HAMMER



Osborne No. 39

This hammer is similar to our popular No.33 magnetic hammer but a little heavier.

Length of head (inches)	Weight of head (oz)	Magnetic face (inches)	Large face (inches)	Weight ea (oz)	UPC No.
5 1/2	9	5/16	7/16	13	56052

12 OZ. HEAD HAMMER



Osborne No. 175-M

This is the heaviest hammer with a hickory handle and bronze head.

Length of head (inches)	Weight of head (oz)	Magnetic face (inches)	Large face (inches)	Weight ea (oz)	UPC No.
6 1/4	12	5/16	7/16	15	56062

NYLON TIP MAGNETIC HAMMER FOR DECORATIVE NAILS

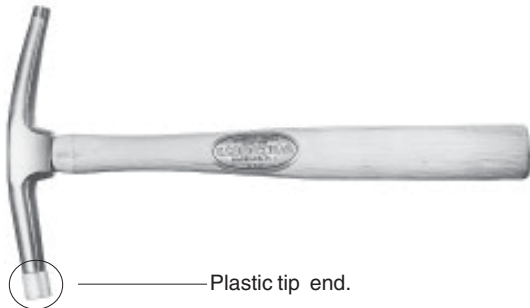

Osborne No. 36

This hammer is similar to our popular No. 33 magnetic hammer but the large face is fitted with a nylon tip. This prevents damage to ornamental nails.

Length of head (inches)	Weight of head (oz)	Magnetic face (inches)	Large face (inches)	Weight ea (oz)	UPC No.
5 1/2	6	1/4	7/16	11	56072

Nylon tips also available separately. **Part No. 36-T UPC No. 56076**

REPLACEMENT HANDLES



Osborne No. 33-H

Replacement handles for above hammers: 33, 36, 39 and 175-M. UPC No. 56046. Wedge included



MAGNETIC UPHOLSTERERS' HAMMER BALANCED

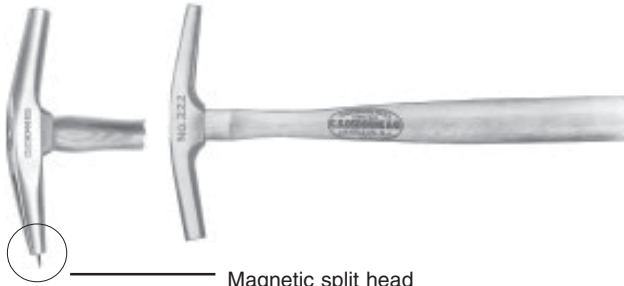

Magnetic split head

Osborne No. 222

Forged steel. Fully polished split head. Hickory handle. A versatile hammer used in many leather trades. Made to U.S. Government specifications.

Length of head (inches)	Weight of head (oz)	Magnetic face (inches)	Large face (inches)	Weight ea (oz)	UPC No.
5 1/2	7	5/16	9/16	13	56012

Osborne No. 222-S

This hammer is the same as the 222 except it has an extra small 1/4 inch face. If this small size is wanted, specify No. 222-S. All other dimensions are the same. UPC No. 56018.

Osborne No. 222-H

Replacement handles also available. UPC No. 56016.

LIGHT MAGNETIC UPHOLSTERS' HAMMER



Osborne No. 111

Forged steel. This hammer is similar to No. 222 but has a lighter weight head.

Length of head (inches)	Weight of head (oz)	Magnetic face (inches)	Large face (inches)	Weight ea (oz)	UPC No.
5 1/4	6	5/16	9/16	7	56022

MAGNETIC TACK HAMMERS



Popular weights and sizes for window trimmers, upholsters and house hold use. Forged from our special tool steel, carefully tempered. Fully polished head.

Osborne No.	Length of head (in)	Weight of head (oz)	Magnetic face (in)	Overall length (in)	Weight ea (oz)	UPC No.
236	3 1/2	4	1/4	11	6	56032
237	4 1/8	5	1/4	11	7	56034
238	4 3/8	7	5/16	10 1/2	11	56036

MAGNETIC NAIL & TACK PLACER



Osborne No. 631

A superior quality nail or tack holder. The 5/8 octagon shank is made of stainless steel with a powerful permanent alnico magnet inserted in the tip. Can be used to set tacks in a tight place.

Size No.	Over length (inches)	Diameter of face (inches)	Weight (oz)	Weight each (oz)	UPC No.
5 1/2	5 1/2	3/8	8	4	56082
8	8	5/8	12	4	56084

RIPPING HAMMER



Osborne No. 277 1/2

Forged tool steel, balanced and tough. Double edged at right angles for stripping off old fabric. A favorite with upholsters.

Length of head (inches)	Width of bits (inches)	Weight ea (lbs)	UPC No.
5	13/16	1 1/4	56162



TACK HAMMER



Osborne No. 1035

Original upholsterer hammer. Forged steel head hardened and polished. Hickory hardwood handle with head end in round shape. Different sizes available. The magnet is inserted in the face. Finishing handle.

Size	Length of head (mm) - (inches)	Weight of head (oz)	Magnetic face (mm)& (inches)	Overall length (mm)&(inches)	Weight ea (oz)	UPC No.
8	135 - 5-1/2	11	8 - 5/16	300 - 12	13	70006
9	135 - 5-1/2	11	9 - 3/8	300 - 12	14	70008
10	135 - 5-1/2	12	10 - 7/16	300 - 12	14	70000

MAGNETIC TACK HAMMER



Osborne No. 1035 M

Same as above but with magnetic split round end. Also three different sizes available.

Size	Length of head (mm) - (inches)	Weight of head (oz)	Magnetic face (mm)& (inches)	Overall length (mm)&(inches)	Weight ea (oz)	UPC No.
8M	135 - 5-1/2	11	8 - 5/16	300 - 12	13	64532
9M	135 - 5-1/2	11	9 - 3/8	300 - 12	14	64546
10M	135 - 5-1/2	12	10 - 7/16	300 - 12	14	64530

TACK HAMMER



Osborne No. 1036

Upholstery hammer with spring stabilized. Hardwood handle. Forged steel head hardened and polished. Hammer end in different round sizes. Also the length of the head is smaller than above hammer.

Size	Length of head (mm) - (inches)	Weight of head (oz)	Magnetic face (mm)& (inches)	Overall length (mm)&(inches)	Weight ea (oz)	UPC No.
10	115 - 4-1/2	11	10 - 3/8	300 - 12	14	70020
11	115 - 4-1/2	11	11 - 3/8	300 - 12	14	70022
12	115 - 4-1/2	12	12 - 7/16	300 - 12	14	70024
13	115 - 4-1/2	13	13 - 1/2	300 - 12	14	70026
14	115 - 4-1/2	13	14 - 1/2	300 - 12	14	70028

MAGNETIC TACK HAMMERS

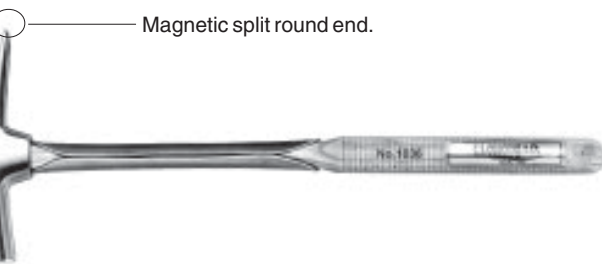

Osborne No. 1036 M

Same as above but with magnetic split round end. Also different sizes are available.

Size	Length of head (mm) - (inches)	Weight of head (oz)	Magnetic face (mm)& (inches)	Overall length (mm)&(inches)	Weight ea (oz)	UPC No.
10M	115 - 4-1/2	11	10 - 3/8	300 - 12	14	70010
11M	115 - 4-1/2	11	10 - 3/8	300 - 12	14	70012
12M	115 - 4-1/2	12	10 - 7/16	300 - 12	14	70014
13M	115 - 4-1/2	13	10 - 1/2	300 - 12	14	70016
14M	115 - 4-1/2	13	10 - 1/2	300 - 12	14	70018

NYLON TIP TACK HAMMER

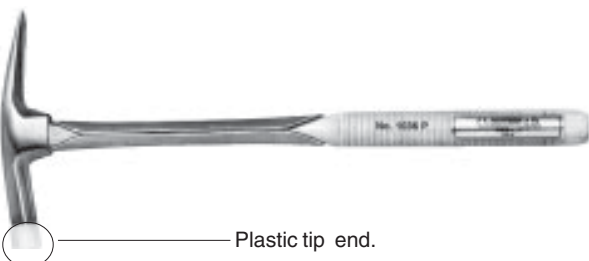

Osborne No. 1036 P

Same upholstery hammer as previous but with plastic tip on one end. Tip only also available separately. Part # 1036 E . UPC No.70030.

Size	Length of head (mm) - (inches)	Weight of head (oz)	Magnetic face (mm)& (inches)	Overall length (mm)&(inches)	Weight ea (oz)	UPC No.
12	115 - 4-1/2	13	12 - 7/16	300 - 12	14	70032
14	115 - 4-1/2	14	14 - 1/2	300 - 12	14	70034



HANDLES & WEDGES.



Osborne No. 1035-36 ST

Replacement hardwood handles for the 1035 and 1036 hammers.

Length of handle (mm) & (inches)	Diameter of the handle (mm) & (inches)	Weight ea (oz)	UPC No.
300mm -12"	16mm - 5/8"	3	70002

Osborne No. 1035-36 STK

Replacement wedges for 1035 & 1036 hammers. UPC No. 70004.

GLAZIER HAMMER



Osborne No. 1066 B

Hardwood handle. Forged steel head fully polished. An industry standard. Accurately finished sides and face for square striking.

Length of head (mm) - (inches)	Weight of head (oz)	Diameter face (mm)& (inches)	Overall length (mm)&(inches)	Weight ea (oz)	UPC No.
110mm 4-1/4"	4	17mm -11/16"	300mm - 12"	6	70042

GLAZIER HAMMER

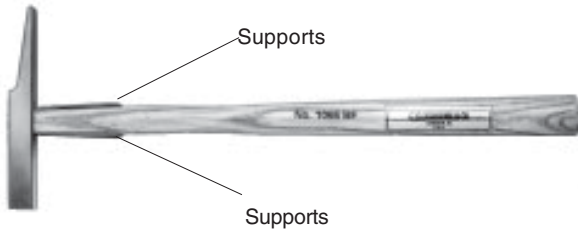

Osborne No. 1066 BF

Same as above glazier hammer but with stabilized spring handle.

Length of head (mm) - (inches)	Weight of head (oz)	Diameter face (mm)& (inches)	Overall length (mm)&(inches)	Weight ea (oz)	UPC No.
110mm 4-1/4"	4	17mm -11/16"	300mm - 12"	6	70044

MAGNETIC TACK HAMMER



Osborne No. 1066 D

Magnetic tack hammer with hardwood handle. Forged steel head hardened and polished with inserted magnet.

Length of head (mm) - (inches)	Weight of head (oz)	Diameter face (mm)& (inches)	Overall length (mm)&(inches)	Weight ea (oz)	UPC No.
110mm 4-1/4"	4	17mm -11/16"	300mm - 12"	6	70046

HANDLES & SUPPORTS



Osborne No. 1066 ST

Replacement hardwood handles with supports for above hammers.

Length of handle (mm) & (inches)	Diameter of the handle (mm) & (inches)	Weight ea (oz)	UPC No.
300mm -12"	22mm - 7/8"	2	70048

RIVETING HAMMER



Osborne No. 57

Forged steel highly polished head. Hardwood handle. Different sizes available.

Size No.	Length of head (inches)	Diameter of face (inches)	Weight of head (oz)	Weight each (oz)	UPC No.
000	3	3/8	2 1/2	4	56082
00	3 3/8	3/8	3	4	56084
0	3 5/8	7/16	4	6	56086
1	4	1/2	5	8	56088
2	4 1/4	9/16	7	12	56090
3	4 1/2	5/8	9	14	56092
4	4 3/4	3/4	12	16	56094



STAPLE LIFTER



Osborne No. 120 1/2

The correct angle for removing staples of any size, from the smallest to the long leg staples and shredded material. Manufactured from top grade steel. Electronically hardened working ends. Easy to grip, plastic handle. This is a very popular model. Not recommended for pulling out tacks.

Blade length (inches)	Overall length (inches)	Weight ea (oz)	UPC No.
4 1/2	6 1/2	4	64006

STAPLE REMOVER



Osborne No. 124

Forged from 4140 alloy tempered steel. A consistently made Osborne quality product. Carefully hardened for lasting use.

Blade length (inches)	Overall length (inches)	Weight ea (oz)	UPC No.
2 1/4	6	4	64014

STAPLE KNOCKER



Osborne No. 120

Staple knocker for removing staples and shredded material. Manufactured from top grade steel. Electronically hardened working ends. Easy to grip plastic handle. Used with Osborne hickory or rawhide mallets.

Blade length (inches)	Overall length (inches)	Weight ea (oz)	UPC No.
4 1/2	6 1/2	4	64004

TACK AND STAPLE REMOVER



Osborne No. 121

This staple and tack remover is constructed with the same honest craftsmanship that goes into all Osborne tools. Can be also used for grooving out drawers so that when reglued they will stick. Made of forged steel with wooden handle.

Blade length (inches)	Overall length (inches)	Weight ea (oz)	UPC No.
2 1/4	6 1/2	2	64010

CLAW TOOL



Osborne No. 200

Narrow at the point to get under heads of ornamental nails and tacks without harming fabric or wood. A popular upholsterer's tool.

Blade length (inches)	Overall length (inches)	Weight ea (oz)	UPC No.
3 1/4	7 1/2	3	64220

STAPLE AND TACK CLAW



Osborne No. 201

A good quality drop forged tack claw. Pointed ends are hardened and tempered to prevent breakage. Similar to 202 but with traditional wooden handle. Flat base.

Blade length (inches)	Overall length (inches)	Weight ea (oz)	UPC No.
2 1/2	7	4	64224

OSBORNE QUALITY STAPLE/TACK REMOVERS



PLASTIC AND TACK CLAW



Osborne No. 202

A quality drop forged tack claw. Ends are hardened and tempered to prevent breakage. Similar to 201 but with rugged plastic handle for heavier use and more leverage.

Blade length (inches)	Overall length (inches)	Weight ea (oz)	UPC No.
2 3/4	6 3/4	4	64226

CLAW TOOL



Osborne No. 122

This claw is especially designed for lifting tacks and small nails. Drop forged steel blade and hardwood handle.

Blade length (inches)	Overall length (inches)	Weight ea (oz)	UPC No.
2 7/8	7 1/4	3	64204

CLAW TOOL



Osborne No. 123 1/2

Boss claw tool. Drop forged blade with 1/2 inch diameter shank. Amber plastic handle. Very sturdy.

Blade length (inches)	Overall length (inches)	Weight ea (oz)	UPC No.
2 5/8	7	6	64210

STAPLE LIFTER



Osborne No. 763

Forged steel nickel plated with comfortable plastic red handle. Designed to dig down and to remove staples quickly.

Blade length	Overall length	Weight ea (oz)	UPC No.
70mm-2-1/4"	170mm-6-1/2"	4	64784

CLAW TOOL



Osborne No. 761/1

The ideal tool for pulling tacks or nails. Forged steel blade, nickel plated. Hardwood pear shaped handle.

Blade length	Overall length	Weight ea (oz)	UPC No.
85mm- 3-1/2"	200mm- 4-1/4"	4	64780

CLAW TOOL



Osborne No. 761 A

Similar to our above claw tool 761/1 but longer.

Blade length	Overall length	Weight ea (oz)	UPC No.
110mm- 4-3/8"	220mm- 8-3/4"	6	64769

CLAW TOOL



Osborne No. 761 B

Similar to our 761 A but with reinforced striking end on the handle.

Blade length	Overall length	Weight ea (oz)	UPC No.
110mm- 4-3/8"	230mm- 9-1/8"	6	64770



CLAW TOOL



Osborne No. 761 P

Similar to our 761 A but with a shiny strong plastic handle.

Blade length	Overall length	Weight ea (oz)	UPC No.
110mm- 4-3/8"	220mm- 8-3/4"	6	64774

REPLACEMENT HANDLES

761 HN



761 HL



Osborne No. 761 HN

Replacement handle for our popular 761 B. Hardwood with reinforced striking end.

Osborne No. 761 HL

Replacement handle for our popular 761W 1/2. Hardwood with reinforced striking end.

Osborne No.	Overall length	Weight ea (oz)	UPC No.
761 HN	120MM 4-3/4"	2	64771
761 HL	125mm 5"	2	64773

CARDED TACK CLAW



Osborne No. 146

Drop forged 1/2 " tempered steel blades. Polished black plastic handle. Carded on yellow background 8-1/2" x 3-1/2". Clear plastic wrapped.

Blade length (inches)	Overall length (inches)	Weight ea (oz)	UPC No.
3 7/8	6 5/8	3	64216

STAPLE LIFTER



Osborne No. 1066

Polished and forged steel blade. Hardwood handle. A European favorite.

Blade length (inches)	Overall length (inches)	Weight ea (oz)	UPC No.
3 5/8	8	3	64018

BENT RIPPING CHISEL



Osborne No. 339

Rugged tool. Carefully hardened.

Cutting edge (inches)	Stock (inches)	Length (inches)	Weight each (lbs) (oz)	UPC No.
1 5/8	7/8	18	2 6	53182

MOULDING LIFTER



Osborne No. 262

Forged from high quality hexagon tool steel. Hardened and tempered. Fully nickel plated. Individually boxed.

Length (inches)	Stock (inches)	Weight ea (oz)	UPC No.
10 1/2	1/2	14	14292



RIPPING CHISEL



Osborne No. 402

A translucent amber handle for quick identification. Perfect balance. Forged steel blade with correct angle on chisel edge. Shouldered tang, tough construction.

Overall Length (inches)	Width of edge (inches)	Weight ea (oz)	UPC No.
8-3/4	9/16	7	53212

BENT RIPPING CHISEL



Osborne No. 761W 1/2

Forged steel blade. Hardwood handle with reinforced striking end bent at the correct angle. Nickel plated.

Blade length	Overall length	Weight ea (oz)	UPC No.
125mm- 5"	245mm-9-3/4"	6	64767

BENT RIPPING CHISEL



Osborne No. 761PH 1/2

Similar to our 761W 1/2 but with durable plastic handle ideal for stronger work.

Blade length	Overall length	Weight ea (oz)	UPC No.
125mm- 5"	245mm-9-3/4"	6	64776

BENT RIPPING CHISEL



Osborne No. 761W 3/4

Similar to our 761W 1/2 but with claw in blade.

Blade length	Overall length	Weight ea (oz)	UPC No.
125mm- 5"	245mm-9-3/4"	6	64768

BENT RIPPING CHISEL



Osborne No. 761PH 3/4

Similar to our 761W 3/4 but with durable plastic handle ideal for stronger work.

Blade length	Overall length	Weight ea (oz)	UPC No.
125mm- 5"	235mm-9-5/8"	6	64778

STRAIGHT RIPPING CHISEL



Osborne No. 762 P

Straight ripping chisel. Forged steel blade. Nickel plated with strong plastic handle for better use.

Blade length	Overall length	Weight ea (oz)	UPC No.
125mm-5"	230mm-9-1/8"	5	64782

COMBINATION TOOL



Osborne No. 402 1/2

A beautifully finished tool with a translucent amber handle designed to fit the hand with perfect balance. Forged highly polished steel blade. Shouldered tang to prevent driving into handle. Combined ripping tool and tack puller.

Blade length (inches)	Overall length (inches)	Weight ea (oz)	UPC No.
3 3/4	8 1/4	6	53216



PINCERS, FLUSH CUT



Osborne No. 93

A rugged forged steel pincer for heavy ripping. Polished flush cut jaws for getting close to a flat surface.

Length (inches)	Weight ea (oz)	UPC No.
8	13	54112

END CUTTING NIPPER



Osborne No. 94

An excellent small nipper. Made of drop forged steel. Black finish, polished jaws. Flush cut.

Length (inches)	Weight ea (oz)	UPC No.
6 3/8	7	54122

DIAGONAL CUTTING NIPPERS



Osborne No. 91

These rugged drop forged nippers are ideal for cutting hog rings and wire. Polished head, black handles, finest industrial quality. Red plastic grips.

Length (inches)	Weight ea (oz)	UPC No.
7 3/8	9	54082

DIAGONAL CUTTING NIPPERS



Osborne No. 3377

These rugged drop forged nippers are ideal for cutting hog rings and wire. Polished head, black handles, finest industrial quality. Red plastic grips.

Length (inches)	Weight ea (oz)	UPC No.
6 7/8	7	54072



SIDE CUTTER-STAPLE REMOVER

Osborne No. 787 A

Forged steel with extra long, pointed cutter. Polished head with vinyl handles. Depth of head aids in removing staples. This is the famous European "vienner".

TOP VIEW



Overall length	Weight ea (oz)	UPC No.
165mm- 6-1/2"	6	64806



FRONT VIEW

DUCK BILL PLIERS

Osborne No. DB1(Serrated jaw) and Osborne No. DB1-S(Smooth jaw)

Made of malleable iron. Jaw width extra wide. Special small finger crook. Nickel plated, popular style. Also available with smooth jaw .



Length (inches)	Width of jaw (inches)	Weight ea (oz)	UPC No.	UPC No. (smooth jaw)
7	1	6	54012	54014

DUCK BILL PLIERS

Osborne No. 98 and 98-S

Finest professional quality. These pliers are drop forged from high carbon steel. The jaws are hardened, tempered and carefully polished.

They are ideal for stretching material in tight place where space is too limited for using the ordinary stretching pliers. **Also available with smooth jaw**
No. 98-S with UPC. No. 54018.



Length (inches)	Width of jaw (inches)	Weight ea (oz)	UPC No.	UPC No. (smooth jaw)
6 1/2	3/4	5	54016	54018

GOOSENECK WEBBING STRETCHER



Osborne No. 253

A hand stretcher to catch the webbing close to the frame with plenty of leverage. Equally efficient for right or left hand. Extra sturdy construction. Approved favorite.

Osborne No. 253-R

Rubber piece for above Webbing Stretcher. UPC No. 64267.

Length (inches)	Width (inches)	Weight ea (oz)	UPC No.
10	4	14	64266



Gooseneck Webbing Stretcher being used with our popular Magnetic Hammer No. 33.

WEBBING STRETCHER (Rubber End)



Osborne No. 255

Webbing stretcher made of hardwood maple with corrugated rubber at one end, and one row of 6 sharpened steel pins at other end.

Length (inches)	Width (inches)	Weight ea (oz)	UPC No.
8	3 1/4	8	64268

PLASTIC STRETCHER (Groove End)



Osborne No. 869 B

Same as above but without rubber piece on one end. Also it has a groove at the the other end which provides better secure when stretching the material.

Overall length (mm)&(inches)	Width (mm) & (inch)	Weight ea (oz)	UPC No.
175 6- 13/16	80 - 3-1/4	6	65130



Groove End

WEBBING STRETCHER (Groove End)



Osborne No. 869 P

Made of hard durable plastic which make it lighter.

Overall length (mm)&(inches)	Width (mm) & (inch)	Weight ea (oz)	UPC No.
175 6- 13/16	80 - 2-7/8	3	65132



Groove End

WEBBING, CANVAS PLIER

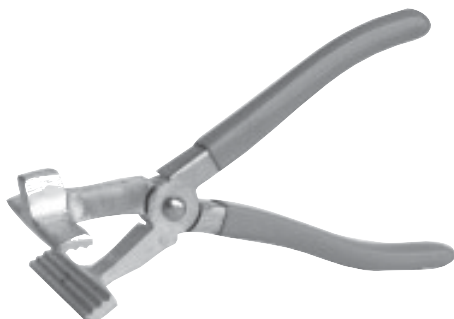

Osborne No. 250

Made with hammer jaw, the hammer acts as a lever if a strong pull is required. Excellent tool for stretching canvas and leather as well as webbing.

Length (inches)	Width of jaw (inches)	Weight ea (oz)	UPC No.
8 1/2	3 3/8	18	54042

WEBBING, CANVAS PLIER



Osborne No. 251

Similar to our above popular No. 250 Webbing, Canvas Plier but with short jaw.

Length (inches)	Width of jaw (inches)	Weight ea (oz)	UPC No.
8 1/2	1 1/2	17	54044

CANVAS STRETCHING PLIER

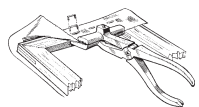

Osborne No. 249

This pliers designed for today's trend to the clean line (or "hard edge") look of canvas made taut over three sides of its wooden stretcher frame.

Parallel extensions permit pressure to be applied to the inner side of the wooden stretcher. Works also on heavy and primed canvas.

Length (inches)	Width of jaw (inches)	Weight ea (oz)	UPC No.
9	3 3/8	18	54046



WEBBING STRETCHER



Osborne No. 252

A handy tool for stretching sagless webbing and punched metal strip webbing.

Length (inches)	Width (inches)	Weight ea (oz)	UPC No.
9	3 1/2	10	64264

WEBBING STRETCHER



Osborne No. 205

Safe - No sharp teeth, English Pattern Webbing Stretcher. Used widely in Great Britain. Made of American Hard Rock Maple. Finely finished. Toughest quality. Can be used with any webbing.

Overall length (inches)	Hole (inches)	Weight ea (oz)	UPC No.
11	2-3/8 x 1/2	8	64262

RUBBER & ELASTIC WEBBING STRETCHER

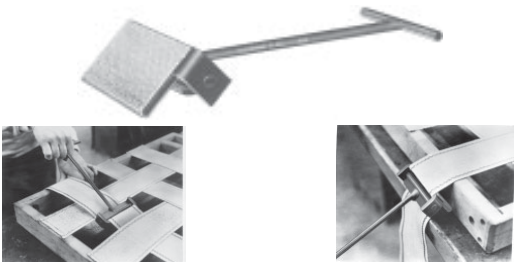

Osborne No. 263

This sturdy stretcher grips without spikes, stretches accurately and evenly. Protects edges of furniture from being marred. Design for rubber webbing but can be used on any webbing.

Length (inches)	Width (inches)	Weight ea (oz)	UPC No.
9 3/4	4 1/4	18	64272

CLIP FOR RUBBER WEBBING



Osborne No. 239

Metal clips used for rubber webbing job. Polished and excellent quality. Packed in two different quantities.

Size	Length (inches)	Each per box	Weight bx (lbs)	UPC No.
S	5	250	4 1/2	14242
L	5	1250	22 1/2	14244

HOOK



Osborne No. 264

Hook for pulling No. 239 clips on Elastic and Rubber Webbing.

Length (inches)	Width (inches)	Weight ea (oz)	UPC No.
6 3/8	2	7	58232

LEVER SPRING STRETCHER



Osborne No. 268

This sturdy tool is used for heavy duty installations and is a safe method for installing sinuous type springs. Just set spring into rear frame clip and then pull spring into position from the front of the frame.

Overall length (inches)	Width of handle (inches)	Weight ea (oz)	UPC No.
17 1/2	1	10	64274

SPRING PULLER HOOK



Osborne No. 297

Can be used in conjunction with the No. 268 Lever Spring Stretcher or by itself.

Overall length (inches)	Width of handle (inches)	Weight ea (oz)	UPC No.
4 1/4	3 1/2	2	58242



SPRING CLIP PLIERS



Osborne No. 445-3

A special pliers for three prong setting spring or edge wire clips. A great saver. No. 445 regular sets Kay or Baker clips.

Length (inches)	Weight ea (oz)	UPC No.
7	2	54222

BW CLIP PLIER



Osborne No. 522

New and improved, *this sturdy quality tools is specially designed for rapid closing of 1/4 : cushion spring (two 8 gauge wire) clips. Contoured handle provides good grip.

Overall length (inches)	Weight ea (oz)	UPC No.
7	2	54232

CLIPS

3 PRONG CLIP

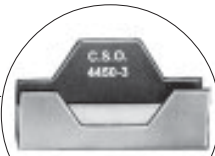

EK CLIP



LINED BW-CLIP



Osborne No. 4450-3

High quality three prong clips for use with our No. 445-3 Spring Clip Pliers.

Osborne No. 4451

High quality EK Clips. Also they are packed 250 clips to a box.

Osborne No. 4452

To be use to attach zig-zag springs, edge springs and torsion springs to border and edge wires. Osborne lined BW Clips won't squeak. Solid steel construction. Osborne No. 522 BW Clip Plier are specially designed for closing BW Clips.

No.	Length (inches)	Width (inches)	Weight per box(lbs)	Each per box.	UPC No.
4450-3	1 1/8	1/2	3	250	14622
4450-5000	1 1/8	1/2	62	5000	14624
4451	7/8	7/8	3 1/4	250	14632
4451-5000	7/8	7/8	66	5000	14634
4452	7/8	1/2	3	100	14633
4452-5000	7/8	1/2	62	5000	14633

TACK STRIP

Osborne No. 4702-214

Staple or tack over edge of fabric to provide a firm even edge. 1/2" wide. Comes in a roll of 214 yards. Weights 3 lbs. UPC No. 78322.



SPRING AND WIRE CONNECTORS

Osborne No. 1776

For furniture and auto seat springs. Fixes broken seat springs and edge wires in minutes. Allen hollow head set screws in heavy tubing for maximum grip.

Each set includes: 8 straight connectors, one 90 degrees connector and one 45 degrees connector plus Allen key. UPC No. 14612. Also sold separately. Please specify size or set when ordering.



Osborne No.	Length (inches)	Width (inches)	UPC No.
1776	SET	3/8	14612
1776-S	2	3/8	14617
1776-45	2	3/8	14613
1776-90	2	3/8	14615



T-NUTS



Osborne No. 5900

High quality T-Nuts clean cut thread for easy installation of legs, casters, etc. Hold fast in any type or wood.

No.	Length (inches)	Hole Width (inches)	Weight per box(lbs)	Each per box.	UPC No.
5900-10-24	5/8	5/8	8	100	78660
5900-1/4-20	5/8	3/16	8	100	78656
5900-5/16-18	5/8	3/8	9	100	78664

SPRING BENDER

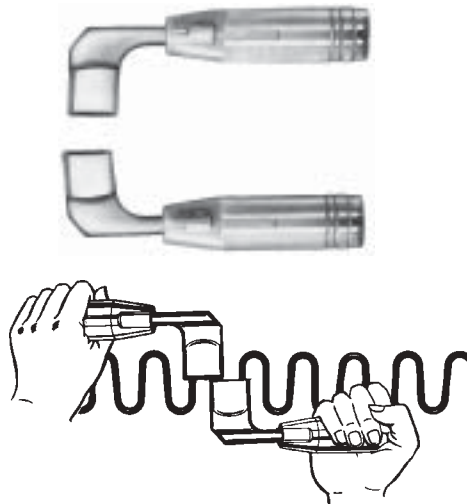

Osborne No. 401

Spring bender, which is both simple in application and efficient in use. Nickel plated ends are slotted to fit loops which can be bent with slight pressure or can be used to unbend previously made bends. This is precisely manufactured so that arcs, angles or curves can be properly made. Available in two sizes.

Size two is not only used on auto seats but also on new furniture.

Please specify size when ordering.

Size No.	Size (inches)	Weight ea (lb)	UPC No.
1	3/8 x 1	1	14312
2	3/8 x 2	2	14314

SPRING END FORMER



Osborne No. 404

Crimps the end of zig-zag springs and open end coil springs.

A tough tool to make work easy. Comes with three bolts and nuts. Bolt to corner of bench or on a 1" block no more than 5" from edge of bench. Can be used in a vise. Drill 5/16" holes 1- 3/4" apart.

Overall length(inches)	Width (inches)	UPC No.
13	1/2	14322

METAL WEBBING STRETCHER (4 IN ONE TOOL)

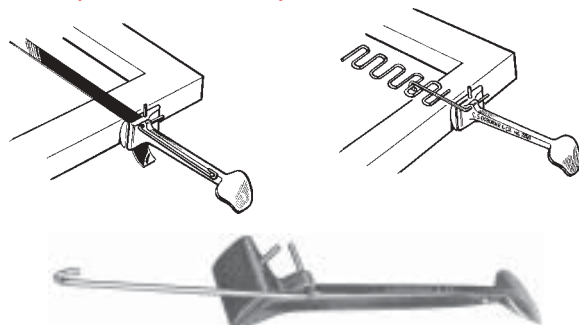

Osborne No. 258

A versatile all metal tool for stretching various types of metal webbing, sagless springs, punched straps, etc. Flat handle gives lots of leverage.

Overall length (inches)	Width (inches)	Weight ea (lbs)	UPC No.
9 1/2	2 1/4	1 1/4	64270



KLINCH-IT TOOL

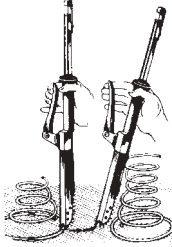

Osborne No. 720

Quick and easy to use. Klinch-it lowers your production cost and increases your production by speeding up one of the greatest time-consuming operations. It eliminates the slow, old fashioned method of sewing springs to the web base. Instead the springs are permanently fastened with sturdy steel clips.

Easy to use instructions

Fill magazine with 2 strips of fasteners, hold tools upright, place nozzle over spring, press down so that prongs of the fastener pierce the webbing, then squeeze lever and fastening is finished.

Overall length (inches)	Width (inches)	Weight ea (lbs)	UPC No.
27	2	3 3/4	14650

KLINCH-IT FASTENERS



Osborne No. 7200

Klinch-it fasteners to be used with our No. 720 Klinch-it tool. Made of high quality steel. Perfect fasteners for furniture use. Packed 5000 per box. Weight per box is of 5000 is 8 1/2 lbs. UPC No. 14652.

HEAVY DUTTY WIRE CUTTER



Osborne No. 719

This workstation wire cutter can be permanently benchmounted or bolted to a plank, for easy transportation to a job site.

Consists of a 3" x 6" base with a 21" long handle. Cuts 1/4" (6mm) medium, hard and non-alloy chain metals.

Then right tool for cutting zig-zag springs, etc.

Base (inches)	Overall length (inches)	Weight ea (lbs)	UPC No.
3 x 6	21	7 1/2	14500

WIRE FORMER

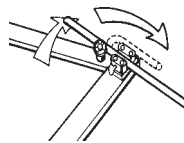

Osborne No. 1963

A tough tool that makes difficult repairs easy. You can quickly bend the ends of no sags, edgewise and form springs right on the spot, making offsets where you need them.

Can be readily mounted in a vise for duplicating complex repetitive wire bends. Designed with heat-hardened steel to give long live.

Overall length (inches)	Width (inches)	Weight ea (lbs)	UPC No.
21	2 3/4	2	14651

DOUBLE WEDGE SPRING SPREADER



Osborne No. 999

For separating double coil platform rocker assembly while attaching to frame.

Overall length (inches)	Width (inches)	Weight ea (lbs)	UPC No.
4 5/8	1 3/8	1 1/4	64504



PATTERN AND CABINET MAKERS STEEL PINCH DOGS



Osborne No. 89

Made from the finest quality high carbon steel. Hardened and tempered for the long duration. Square corners over edges make easy driving. Different sizes available.

Size No.	Length (inches)	Weight ea (oz)	UPC No.
3/4	3/4	1	64132
1	1	1	64134
1 1/4	1 1/4	1	64136
1 1/2	1 1/2	1	64138
2	2	1	64140
2 1/2	2 1/2	2	64142
2 3/4	2 3/4	2	64144
3	3	2	64146
3 1/2	3 1/2	2	64148

ALUMINUM RULE (inches and metric)

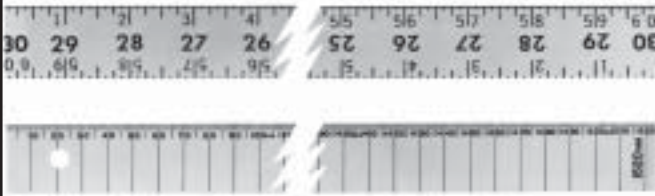

Osborne No. 161

Made of anodized aluminum. One side shows graduation in inches along both edges with measurements also from center of rule. When turned over, the opposite side of the rule has graduations in metric along one side. Hole on one end for hanging display.

Length (inches)	Width (inches)	Thickness (inches)	Weight ea (oz)	UPC No.
60	1 1/2	1/8	8	64092

ALUMINUM STRAIGHT EDGE RULE



Osborne No. 60SE

This is one of the finest measuring rules on the market. Markings on one side only. Heavy wide aluminum. Hole punched on one end for hanging display.

Length (inches)	Width (inches)	Thickness (inches)	Weight ea (oz)	UPC No.
60	2	1/8	26	64082

ALUMINUM STRAIGHT EDGE RULER



Osborne No. 802

One edge for standard measurements, one edge for metric. Sturdy and wide - just right for marking selvage edge of cloth. Scales etched in black on silver background, one side only. Finish anodized for permanence. Three lengths available. Hole punched on one end for hanging display.

Length (inches)	Width (inches)	Thickness (inches)	Weight ea (oz)	UPC No.
36	1 1/2	1/8	9	64094
54	1 1/2	1/8	13	64096
60	1 1/2	1/8	15	64098

WOOD RULE



Osborne No. 160

Made from properly dried northern hard maple to meet all state measuring standards. Smooth finished in clear lacquer. Has 1/8" calibrations. Brass ends. Hole punched on both ends for hanging display.

Size No.	Length (inches)	Width (inches)	Thickness (inches)	Weight ea (oz)	UPC No.
5C	60	1 3/4	1/4	12	64086
6C	72	1 3/4	1/4	18	64088



BUTTON AND FOAM CUTTERS
For perfect Buttons and Easier Poly Foam Tufting

FABRIC CUTTERS FOR BUTTONS

Osborne No. 1212



Polished, high quality and sharpen with the best technique. Cuts up to 30 buttons at time. Additional sizes upon request.

Button No.	Diameter of button (inches)	Diameter of Cutter (inches)	Weight each (oz)	UPC No.
1212-22	1/2	1	2	64562
1212-30	3/4	1 1/4	2	64564
1212-36	7/8	1 7/16	3	64566
1212-40	1	1 1/2	4	64568
1212-45	1 1/4	1 3/4	4	64570
1212-W	Wood Jig		12	14576

FOAM CUTTERS

Osborne No. 1212



Button No.	Diameter of Cutter (inches)	Weight each (oz)	UPC No.
1212 1/2	1/2	2	64534
1212 3/4	3/4	2	64536
1212 7/8	7/8	3	64538
1212 1	1	3	64540
1212 1 1/8	1 1/4	4	64542
1212 1 1/4	1 1/4	4	64544
1212 1 1/2	1 1/2	4	64548
1212 1 3/4	1 3/4	4	64550
1212 1 7/8	1 7/8	4	64551

Same as above cutters but with some more sizes. Can be ordered either way.

BUTTON AND FOAM CUTTER KIT

Osborne No. K-1212



Kit contains 1", 1 1/4", 1 1/2" diameter cutters with jig and ejector rod. Cuts fabric, vinyl, poly, foam and other soft materials.

For use in a standard 1/4" or 3/8" electric drill. Cutters have special carbonized hardened edge. Weights approximately two pounds. UPC No. 14532.

WOOD JIG

Osborne No. 1212-W



Hardwood jig sold separately also. Ideal for better results and perfect cuts.

Overall length (inches)	Width (inches)	Weight ea (oz)	UPC No.
11	3 1/2	11	14576



U-CUT FOAM & RUBBER SLICER



Overall length (inches)	Width (inches)	Weight ea (lbs)	UPC No.
46	17	7 1/2	14352

Osborne No. 410

U-Cut is fast, flexible and flexible. Place U-Cut on a table or on a flat surface with the slab of material to be cut. The desired cutting thickness is quickly obtained by means of an adjustable screw setting. The operator then merely pushes and pulls U-Cut in a saw-like action and, make wedges, curves, arcs and other special shapes. See illustrations.

These are used particularly for orthopedic seating in autos, as well as furniture.

U-Cut will cut from a minimum of 1/4" to a maximum thickness of 9". Material up to 36" in width and unlimited length can be processed. Pieces can be glue salvageable material.

Extra blades available. **OSBORNE No. 410-B UPC No. 14354**

BLIND STITCHING SEAM STRETCHER



Osborne No. 267

Made of light aluminum, simple toggle clamp construction. Easy to operate. Minimum length 12" for pillows, maximum length 3 ft. Rigid when in use. Can also be used as calipers for cutting large circles and for blind stitching. Easy to follow instructions on each package. Points easily replaced high quality tool.

Overall length (inches)	Weight ea (onz)	UPC No.
40	12	64276

PIN REMOVER & PIN RESETTER



Osborne No. 96

For use with La-Z Boy Chair. This unique tool does a complete job. Removes and resets. Permits easy access to retaining key pin. One shot in and out.

Overall length (inches)	Width (inches)	Weight ea (oz)	UPC No.
13	1	16	64162

PIPING OR CHANNELING TINS



Osborne No. 412

These 36" long piping tins are made of smooth aluminum. Stuffing channeling. No burs to catch on fabrics, the material is soft so tins can be bent and adjusted. Comes in three different sizes for your best convenient. Please specify size when ordering.

Size No.	Overall length (inches)	Width (inches)	Weight pr. (oz)	UPC No.
2	36	2	15	64362
3	36	3	15	64364
4	36	4	16	64366

CASTOR SOCKET REMOVER



Osborne No. 87

Hardened threaded end that securely screws into socket. Slide hammer knocks it out. Work with our **T-NUTS No. 5900**.

Overall length (inches)	Width (inches)	Weight ea (lbs)	UPC No.
12 1/2	1 1/2	1 1/2	64002

Tips also available separately. **Part No. 87-TIP UPC No. 80058**



TRIMMERS'S STUFFING IRON



Osborne No. 118

A stuffing iron made specially for the trimmer. Hand forged fine quality steel, polished complete. Top quality.

Overall length (inches)	Width (inches)	Weight ea (oz)	UPC No.
16		4	64182

FLAT STUFFING ROD



Osborne No. 119

Forged steel stuffing rod. Slight curve at working end. Flexible Length 16 inches. Width at points 5/8 inches. Top quality.

Overall length (inches)	Width (inches)	Weight ea (oz)	UPC No.
16	5/8	6	64184

PRESSED STEEL STUFFING IRON



Osborne No. 40M-18

A utilitarian stuffing iron, 18" long. Creased in the center to give rigidity.

Overall length (inches)	Width (inches)	Weight ea (oz)	UPC No.
18	3/4	6	64074

FILLER BAZOOKA



SAVE TIME AND MONEY WITH THIS HIGH PERFORMANCE JET STREAM.

Osborne No. 302

Now fill cushions, pillows, pillows backs, mattresses, mattress pads and much more the easy way. Turn tedious job into a simple one by placing the back end of the Bazooka just above the loose filler container and the front end into the item to be filled. In seconds, the Bazooka literally sucks the loose filler into the sleeve being filled, saving approximately 98% of the mess and waste. It's also a vacuum cleaner.

- * Can be used with down, kapok, shredded foam, styrofoam pellets and other loose materials.
- * Bright, lightweight aluminum - 28" length, 2" outside diameter.
- * Operates on 60 to 90 lbs. of pressure.
- * Completely assembled and ready for immediate use.

Overall length (inches)	Diameter of end (inches)	Weight ea (lbs)	UPC No.
28	2	3	10302

RAT BAG



Osborne No. 303

Filter Sock. Comes assembled with ties ready to be attached to the end of the Bazooka. It is made out of Reemay (nonwoven) media similar to quilt matting. It has an inside diameter of 6".

Length (inches)	Width (inches)	Weight ea (oz)	UPC No.
19	2 1/2	4	10304



QUICK NAILER



Osborne No. 777

FANCY NAIL SPACER FOR SPACING ANTIQUE NAILS.

Set up to 5 nails head to head at one time without damaging the furniture, or your fingers. Exact spacing at the same time!

Load large end of tool making sure nails are perpendicular to and shanks are flush with base of tool. Position tunneled section of tool over last nail driven and being setting nail. Removal of tool may require twisting motion and/or pressure against nail heads with free hand. Use Osborne No. 36 Nylon tip hammer for best results.

Overall length (inches)	End Width (inches)	Weight ea (oz)	UPC No.
7	3 1/2	2	64502

Patent No. 4079764

ANTIQUÉ NAIL PLIER



Osborne No. 601

Hardened steel, top quality. Very convenient size for your removing antique nails.

Overall length (inches)	Width (inches)	Weight ea (oz)	UPC No.
7	1 3/4	6	54212

DECORATIVE NAILS

Osborne quality steel nails with natural brass finish. Please specify length and style. Each pattern should be ordered by length of nail. They are packed 1000 each per box. Weight per box 2 lbs.

	No.	Type	Sizes	1M Nails per box UPC No.	1M Nails per box, packed 1C per poly bag	UPC No.	Poly Bag (please designate by using style number + "S")
	680	Oxford Hammered	1/2" 5/8" 3/4"	14442 14444 14446	680S	14447 14449 14448	
	681	French Natural Small	1/2" 5/8" 3/4"	14452 14454 14456	681S	14457 14459 14458	
	682*	French Natural Regular	1/2" 5/8" 3/4"	14462 14464 14466	682S	14467 14469 14468	
	683	Daisy Ornamental	1/2" 5/8" 3/4"	14482 14484 14486	683S	14487 14489 14488	
	684	Overlap	1/2" 5/8" 3/4"	14492 14493 14494	684S	14495 14498 14496	
	685	Spanish Lg. 5/8" dia.	1/2"	14497	685S	14499	

* Osborne No. 682, also available in nickel plated.



STARTER UPHOLSTERY KIT

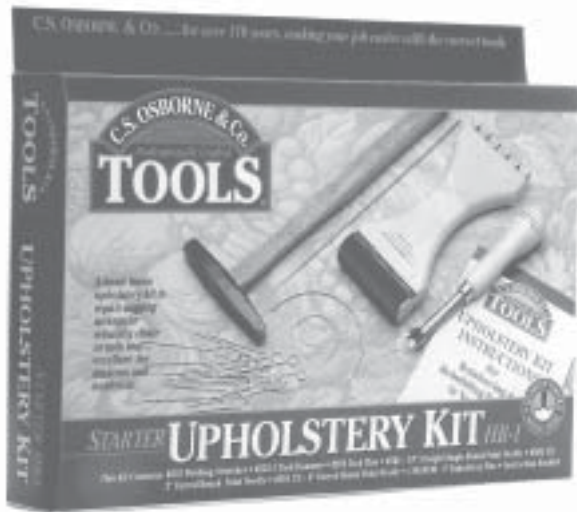

Osborne No. HB-1

A basic home upholstery kit to repair sagging springs or rebuild a chair or sofa. Excellent for students and hobbyists. Professional box cover pictures all tools. Box is designed for hang up display. Weighs 1-1/2 lbs. UPC No. 14070.

EACH KIT CONTAINS			
Quantity each	Osborne No.	Description	UPC No.
1	222-C	Magnetic Hammer	56014
1	255	Webbing Stretcher	64268
1	201	Tack Claw	64224
1	501-1/2 3	Curved Needle	15136
1	501-1/2 6	Curved Needle	15144
1	504-10	Straight Needle	15370
36	190 3	Upholstery Pins	15932
1	B-1 Book	Instruction Booklet	14044

DO IT YOURSELF KIT



Osborne No. B-4

The perfect kit for the upholstery work. Includes easy to follow instruction booklet. Professionally boxed for hang up display. The box cover pictures all tools in kit. Weighs 1-1/2 lbs. UPC No. 14050.

EACH KIT CONTAINS			
Quantity each	Osborne No.	Description	UPC No.
1	222-C	Tack Hammer	56014
1	255	Webbing Stretcher	64268
1	146	Claw Tool	64216
1	504-6	Straight Needle 6"	15366
1	501-1/2 3	Curved Uph. Needle 3"	15136
1	501-1/2 4	Curved. Uph. Needle 4"	15140
1	B-1 Book	Instruction Booklet	14044



INTERMEDIATE UPHOLSTERY KIT



Osborne No. B-11

This kit contains the basic tools and needles required for reupholstery work, but in it, we have eliminated a few of the more expensive professional items in order to bring the cost down to a more popular level for use by schools or other institutions. It serves as an intermediate kit between our popular B-1 Upholstery Kit and the B-7 Pro Upholstery Kit. Professional box cover pictures all tools in kit. Weighs 2-1/2 lbs. UPC No. 14062.

EACH KIT CONTAINS			
Quantity each	Osborne No.	Description	UPC No.
1	222-C	Tack Hammer	56014
1	253	Gooseneck Webbing Stretcher	64266
1	120 1/2	Staple Lifter	64006
1	402	Ripping Chisel	53212
1	76 1/2	Square Point Knife	60046
1	520-8	Regulator	66064
1	501-1/2 3	Curved Needle	15136
1	501-1/2 4	Curved Needle	15140
1	501-1/2 6	Curved Needle	15144
1	502-1/2 4	Curved Needle	15270
1	504-8	Straight Needle	15368
1	684 10	10" Shears	14430
36	190 3	3" Upholstery Pins	15932
1	88-WH	Taylor Chalk - White	65134
1	B-1	Instruction Booklet	14044

PRO UPHOLSTERY KIT



Osborne No. B-7

This all-inclusive kit fills the needs of the journey man upholsterer, the trainee and the ambitious amateur. It contains twelve items of top quality C.S. Osborne tools and needles, also free instruction booklet. Professionally boxed. Box cover pictures all tools.

Weighs 5 lbs. UPC No. 14056.

EACH KIT CONTAINS			
Quantity each	Osborne No.	Description	UPC No.
1	33	Bronze Magnetic Hammer	56042
1	253	Gooseneck Webbing Stretcher	64266
1	120 1/2	Staple Lifter	64006
1	402	Ripping Chisel	53212
1	76 1/2	Square Point Knife	60046
1	396-2	White Rubber Mallet	61018
1	306-1/2 8	Light Regulator 8" 9 Gauge	16034
1	K-3	Needle Card	15014
1	K-5	Needle Card	15018
1	684 10	10" Shears	14430
36	190 3	3" Upholstery Pins	15932
1	88-WH	Taylor Chalk - White	65134
1	B-1	Instruction Booklet	14044

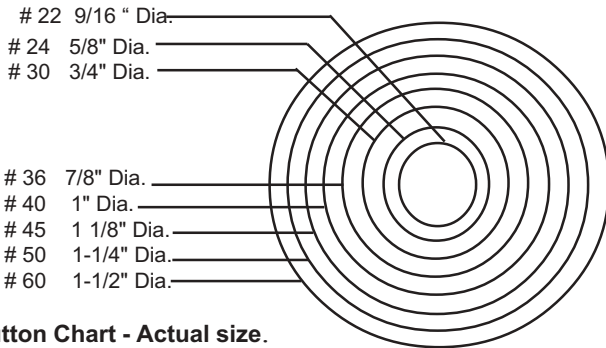

Button Chart - Actual size.

What is Required to Cover Buttons??

FIRST, A Button Covering and Cutting Machine (see below).
 SECOND, Steel Cutters and Covering Dies(see page 29-30). A separate set of dies is required to make each size of button to get a perfect finished of quality. Always use the correct top die for your material.
 THIRD, Buttons Molds (see page 36). A complete mold necessary to make a button consists of a shell and a back. The shell is covered and crimped around the back by the die. Always use the correct shell for your material.

CHART OF BUTTON SIZES

The standard measurement for buttons is 40 lignes per inch. Therefore size 30 is 3/4", size 60 is 1-1/2", etc. Dimensions shown are for buttons before covering.

No.1 HAND BUTTON COVERING MACHINE



Osborne No. W-1

High quality hand machine. Cuts fabric and covers buttons. Use 2 pcs. Die and short cutters. The No. 1 Button machine has a reinforced frame and handle. Bolts to a table for added stability. Comes complete with a wood block for cutting covers. It produce 80 to 120 buttons per hour. Also used to set snaps, grommets and ventilators. Wood block and dowel can be also purchased separately.
 Dies for setting snaps ,grommets, ventilators are also available.

Osborne No.	Height (inches)	Weight ea (lbs)	UPC No.
W-1	22	16	75000

EXTRA PARTS		
Osborne No.	Description	UPC No.
W-1H	Handle for#1 Machine	75008
W-1P	Pin for # 1 Machine	75012
W-1PL	Plate for # 1 Machine	75014
W-1 Spring	Top Spring for W-1 Machine	75002

No.2 HAND BUTTON COVERING MACHINE



Osborne No. W-2

Same as our popular W-1 Button machine but faster. Used with 3 piece Swivel Dies and long cutters for fast production. Heavy ribbed construction Long handle for extra leverage. Comfortable plastic handle grip allow operator to work at higher speed. Makes a production of 180-250 buttons per hour. Also used to set snaps, grommets and ventilators.
 Dies for setting snaps and grommets are also available.

Height (inches)	Weight ea (lbs)	UPC No.
23	22	75016

EXTRA PARTS		
Osborne No.	Description	UPC No.
W-2 Spring	Top spring for Machine	75020
W-2H	Handle for Machine	75018



BUTTON DIES

All dies are precision machined, nickel plated and made of high quality steel. Cutters are heat treated and have sharp edges engineered for accurate cutting and long life.

TYPE AND SIZE: The Button Machine No.1 uses 2 pcs. The No. 2 uses 3 pcs. Dies.

MATERIAL THICKNESS. Always buy a set of dies made exactly for your material thickness. If you have a variety of material thickness, you will need more than one set of dies. Trying to cover very thin and very thick material with the same set of dies will result in poor quality buttons. If you are not sure what dies to buy, send us a sample of your material and we will assist you in the proper selection.

Description	Die Designation
Light Material	LU
Regular Material	HU
Heavy Material	HUX

TO SELECT THE PROPER DIE USE THIS TABLE

DIE WITH CUTTER SETS.

Sets of Dies with Cutters are most popular. Sets are available for W-1 Button machine, which uses the 2 piece dies with short cutter, and for W-1, which uses 3 piece dies with long cutter. When you order, make sure to specify the type of material : HU, HUX or LU, depending on thickness of the material to be used. Following are the part numbers for "HU" dies with cutter for W-1 and W-2 Button Machines.



2 PIECE DIE & CUTTER SET

USED WITH W-1 BUTTON COVERING MACHINE

2 PCS. DIE "HU" AND CUTTER FOR W-1 (ALSO AVAILABLE IN "LU" AND "HUX")								
Osborne No.	WDIHUC222	WDIHUC242	WDIHUC302	WDIHUC362	WDIHUC402	WDIHUC452	WDIHUC502	WDIHUC602
Size	22	24	30	36	40	45	50	60
UPC No.	75948	75956	75964	75972	75980	75988	75996	76004



3 PIECE DIE & CUTTER SET

USED WITH W-2 BUTTON COVERING MACHINE

3 PCS. DIE "HU" AND CUTTER FOR W-2								
Osborne No.	WDIHUC223	WDIHUC243	WDIHUC303	WDIHUC363	WDIHUC403	WDIHUC453	WDIHUC503	WDIHUC603
Size	22	24	30	36	40	45	50	60
UPC No.	75952	75960	75968	75976	75984	75992	76000	76008

*Also available in LU AND HUX

SHORT CUTTER



Cutters are also available individually. High quality steel hardened and tempered assures long life. Sharp edges engineered for accuracy. The short cutter is used to cut the fabric. Works with our W-1.

SHORT CUTTER ONLY FOR W-1 BUTTON COVERING MACHINE								
Osborne No.	WCUSL22	WCUS24	WCUS30	WCUS36	WCUS40	WCUS45	WCUS50	WCUS60
Size	22	24	30	36	40	45	50	60
UPC No.	75764	75768	75772	75778	75782	75786	75790	75794

LONG CUTTER

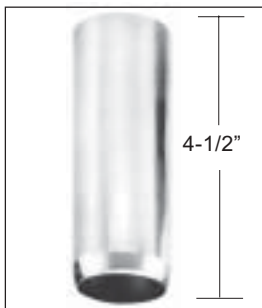

High quality steel hardened and tempered assures long life. Sharp edges engineered for accuracy. The long cutter is used to cut the fabric. Works with our W-2.

LONG CUTTER ONLY FOR W-2 BUTTON COVERING MACHINE								
Osborne No.	WCUL22	WCUL24	WCUL30	WCUL36	WCUL40	WCUL45	WCUL50	WCUL60
Size	22	24	30	36	40	45	50	60
UPC No.	75732	75736	75738	75744	75748	75752	75756	75760



DIE WITH CUTTER SETS.



Button dies are also available individually for all three type of material HU, HUX or LU for both button machines W-1 and W-2. Please specify the thickness when ordering.

Following are the part numbers for "HU" dies.

USED WITH W-1 BUTTON COVERING MACHINE

2 PCS. DIE "HU" AND CUTTER FOR W-1(ALSO AVAILABLE IN "LU" AND "HUX")								
Osborne No.	WDIHUC222	WDIHUC242	WDIHUC302	WDIHUC362	WDIHUC402	WDIHUC452	WDIHUC502	WDIHUC602
Size	22	24	30	36	40	45	50	60
UPC No.	75948	75956	75964	75972	75980	75988	75996	76004

USED WITH W-2 BUTTON COVERING MACHINE

3 PCS. DIE "HU" ONLY (ALSO AVAILABLE IN LU AND HUX).								
Osborne No.	WDIHU223	WDIHU243	WDIHU303	WDIHU363	WDIHU403	WDIHU453	WDIHU503	WDIHU603
Size	22	24	30	36	40	45	50	60
UPC No.	75884	75892	75900	75908	75920	75928	75936	75944

GROMMET DIES



High quality dies to set grommets. Different sizes available. These grommet dies work only with our No. W-1 Button Machine. Prices available upon request for Grommet Dies for W-2 Machine sizes 0-5.

2 PCS. GROMMET DIES FOR No. 1 BUTTON MACHINE								
Osborne No.	WDIGR00	WDIGR0	WDIGR1	WDIGR2	WDIGR3	WDIGR4	WDIGR5	WDIGR25
Size	00	0	1	2	3	4	5	25
UPC No.	75852	75848	75856	75860	75868	75872	75876	75864

SNAP DIES



These dies are used for setting three and four piece snaps. Available for our W-2 and W-2 Machines. Please specify type when ordering.

SNAP DIES FOR FOUR PIECE SNAPS		
Osborne No.	WDISN41	WDISN42
UPC No.	76284	76288
Work with	W-1	W-2

SNAP DIES FOR THREE PIECE SNAPS		
Osborne No.	WDISN31	WDISN32
UPC No.	76276	76280
Work with	W-1	W-2

VENTILATOR DIES



Precision machined. High quality steel. Used to set ventilators with our W-1 Button Machine.

Osborne No.	Description	UPC No.
WDIV1	1" ventilator die for W-1	76292
WDIV1S	3/4" Ventilator die for W-1	76300
WDIV2	1" Ventilator die for W-2	76304



WIRE EYE BUTTONS BACKS ONLY

High quality buttons backs also called Wire Eye. Two styles available: No. 9 and No. 44. Wire eye No. 9 Standard has a heavy eye and will withstand a heavy pullout test. The No. 44 has a smaller eye and is intended to be used against delicate material to minimize piercing and runs.

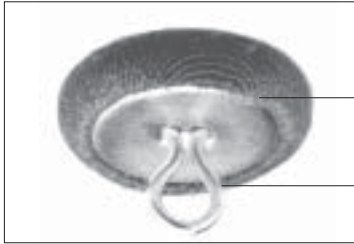

9

Strong wire eye.
Large opening for ease of threading tufting twine.

Uniform Dimensions.
Smooth edges help avoid cutting even the most difficult materials.
Perfectly rounded loop won't fray twine.

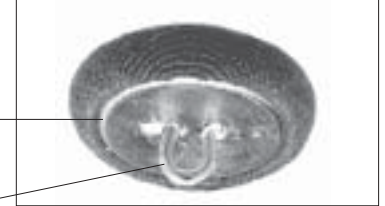

44

The wire eye is a little smaller, and specially designed to prevent fabric damage and pull through in delicate materials.

No. 9 WIRE EYE BUTTON BACK ONLY 5 GROSS BOX (ALSO AVAILABLE IN 1, 25 AND 50 GROSS BOXES).

Osborne No.	VWVE229-5	VWVE249-5	VWVE309-5	VWV369-5	VWVE409-5	VWVE459-5	VWVE509-5	VWVE609-5
Size	22	24	30	36	40	45	50	60

No. 44 WIRE EYE BUTTONS BACK ONLY 5 GROSS BOX (ALSO AVAILABLE IN 1, 25 AND 50 GROSS BOXES).

Osborne No.	VWVE2244-5	VWVE2444-5	VWVE3044-5	VWV3644-5	VWVE4044-5	VWVE4544-5	VWVE5044-5	VWVE6044-5
Size	22	24	30	36	40	45	50	60

SHELLS

High quality Shells which are the top part of button. We offer four kinds of shells: ALUMINUM Shells, RUST RESISTANT Shells, REGULAR Shells and BLACK SOFT Shells. Black Soft Shells are the most popular since they prevent tearing of the materials. Rust Resistant Shells minimize rusting problems and the resultant damage to the upholstery. We sell shells in four quantities: 1, 5, 25 and 50 gross boxes. The most popular quantity is 5 gross box. Please specify when ordering; if not we will ship 5 gross boxes.

BLACK OXIDE SOFT SHELL 5 GROSS BOX (ALSO AVAILABLE IN 1, 25 & 50 GROSS BOX).

Osborne No.	WSHS22-5	WSHS24-5	WSHS30-5	WSHS36-5	WSHS40-5	WSHS45-5	WSHS50-5	WSHS60-5
Size	22	24	30	36	40	45	50	60

REGULAR SHELL 5 GROSS BOX (ALSO AVAILABLE IN 1, 25 AND 50 GROSS BOXES).

Osborne No.	WSHR22-5	WSHR24-5	WSHR30-5	WSHR36-5	WSHR40-5	WSHR45-5	WSHR50-5	WSHR60-5
Size	22	24	30	36	40	45	50	60

ALUMINUM SHELL 5 GROSS BOX (ALSO AVAILABLE IN 1, 25 & 50 GROSS BOX).

Osborne No.	WSHA22-5	WSHA24-5	WSHA30-5	WSHA36-5	WSHA40-5	WSHA45-5	WSHA50-5	WSHA60-5
Size	22	24	30	36	40	45	50	60

RUST PROOF PLATED SHELL 5 GROSS BOX (ALSO AVAILABLE IN 1, 25 & 50 GROSS BOX).

Osborne No.	WSHRR22-5	WSHRR24-5	WSHRR30-5	WSHRR36-5	WSHRR40-5	WSHRR45-5	WSHRR50-5	WSHRR60-5
Size	22	24	30	36	40	45	50	60



Black Soft Shell

Rust Proof Shell

Aluminum Shell

Regular Shell



PRONG

Also known as Clinch Buttons. Great for high speed production. Used on headboards, bars, restaurant booths and wide range of furniture styles. Very effective for pre-tufting of covers before attachment to the furniture frame.

Round edge helps prevent holes from enlarging after application.

Wire is precision tempered. Just the right hardness to keep prongs from pulling out, yet easy for your installer to bend.

Leg is longer for ease of bending.

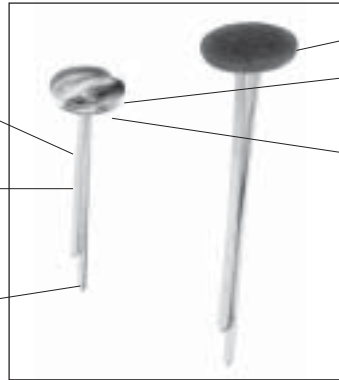

Shell with material

Staked edges are rounded to prevent material from tearing.

Prong wire is solidly staked to collet for safety and ease of installation.

PRONGS FIVE GROSS BOX (ALSO AVAILABLE IN 1, 25 AND 50 GROSS BOX).									
Osborne No.	WPR22112-5	WPR222-5	WPR22212-5	WPR242-5	WPR24212-5	WPR30112-5	WPR302-5	WPR30212-5	WPR303-5
Size	22			24		30			
Lenght(inches)	1 1/2	2	2 1/2	2	2 1/2	1 1/2	2	2 1/2	3

PRONGS FIVE GROSS BOX (ALSO AVAILABLE IN 1, 25 AND 50 GROSS BOX).							
Osborne No.	WPR36112-5	WPR362-5	WP362-5	WPR36212-5	WPR40112-5	WPR402-5	WPR452-5
Size	36				40		45
Lenght(inch)	1 1/2	2	2 1/2	2	2 1/2	1 1/2	2

PRONG WASHERS

Use for extra safety in preventing prongs from pulling out. Different sizes available for best results.

Prong shown with washer

PRONG WASHERS 5 GROSS BOX(Also availbe in 1, 25 & 50 gross box).					
Osborne No.	WWAM1-5	WWAM138-5	WWAF138-5	WWASP10-5	WWASP15-5
Description	Metal Washer # 1	Metal Washer # 3	Fibre Washer # 5	Spring Washer # 10	Spring Washer # 15
D. Size(inch)	1	1 3/8	1 3/8	5/16 x 7/8	15/16

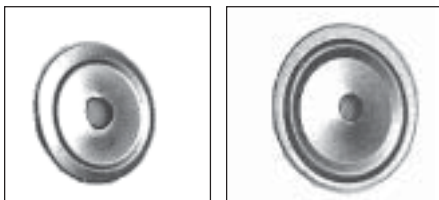
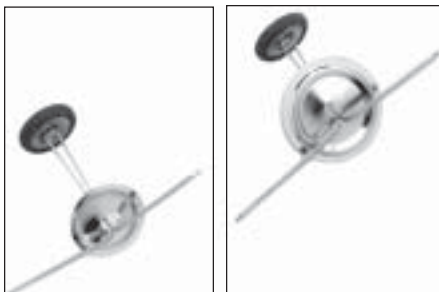

Metal 1"
No. 1 Washer
Beveled for additional strength.

Metal 1 3/8"
No. 3 Washer
Extra wide, more holding area.

(PLEASE CHANGE LAST NUMBER TO SPECIFY QUANTITY WHEN ORDERING 1, 25 OR 50 GROSS).

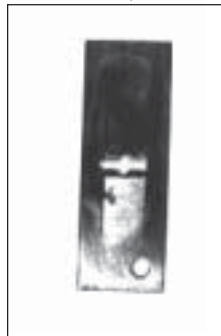

Metal 5/16"x7/8"
No. 10 Spring Metal Washer
For use with threaded nails. Perfect for working near edges or corners.

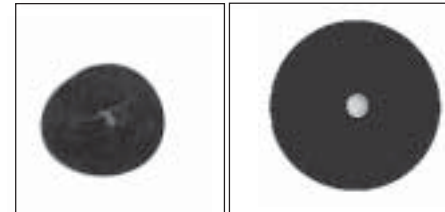
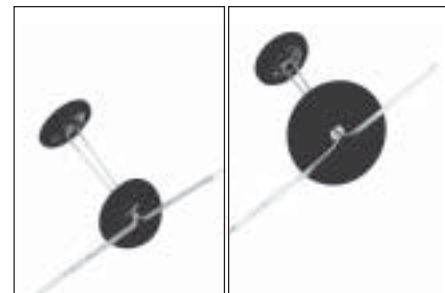

Metal 15/16
No. 15 Spring Washer
Precision tempered springs steel.

Fibre 1 3/8"
No. 5 Washer
Fibre Washer is strong and squeak proof



THREADED NAILS (For use with Spring Washer)

Nail is rigidly welded to no dent collet.

Deep threads are designed so washer slides on easy, yet can't pull off.



When anchored with a spring lock washer, the Threaded Nail is a fast, positive, alternative to prong tufting. Just insert the nail through the upholstered construction and fasten in on the back with a spring washer.



Threaded nail & Spring washer

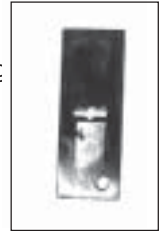

Please specify quantity when ordering.

THREADED NAILS 5 GROSS BOX (ALSO AVAILABLE IN 1, 25 & 50 GROSS BOX).										
Osborne No.	WTN22785-5	WTN22112-5	WTN222-5	WTN2478-5	WTN3078-5	WTN30112-5	WTN302-5	WTN3678-5	WTN36112-5	WTN362-5
Size	22			24	30			36		
Length(inch)	7/8	1-1/2	2	7/8	7/8	1-1/2	2	7/8	1-1/2	2

CORRUGATED NAILS (no dent)

No dent collect. Nail is securely welded to collet.

Hardened steel.

Nail thickness 0.083"



Hardened and tempered steel nail. For driving into wood. Buttons are driven through fabric and foam directly into frame. Small corrugations allow for easy driving, help prevent buttons from pulling out. No dent collet. Nail is securely welded to collet.

Please specify quantity when ordering.

NAIL BUTTON DRIVING TOOL



Osborne No. 915

Has a concave head to prevent the nail button from being damaged when hammered. Specify the size of your button when ordering.

Length (inches)	Weight per box (oz)	UPC No.
4 1/2	2	76350

NO DENT NAILS 1 GROSS BOX												
Osborne No.	WND2234-1	WND2278-1	WND221-1	WND3034-1	WND301-1	WND30114-1	WND30112-1	WND3634-1	WND361-1	WND36114-1	WND361316-1	WND451-1
Size	22			30				36				45
Length(inch)	3/4	7/8	1	3/4	1	1-1/4	1-1/2	3/4	1	1-1/4	1-3/16	1

* Also available in 5, 25 and 50 Gross Boxes.

UNASSEMBLED NYLON SNAPS

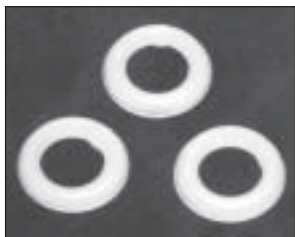

Also called Plastic Snaps Rings. Two different sizes available. Ideal for use on furniture, recreational vehicles, manufactured housing, etc. This nylon back is specially designed to snap onto a Durable Wood Screw or Durable Snap when covered. This provides a secured hold with little chance of rust or discoloration. **Sold with and without shells.**

UNASSEMBLED SNAPS ONLY 1 GR. BOX		
Osborne No.	WPSR30-1	WPSR36-1
Size	30	36

* Also available in 5, 25 and 50 Gross Boxes.

Please specify quantity when ordering.

PLASTIC DOMED BUTTON



Ready to use button.No. 40 available only. Made of Nylon one piece construction. Available in: dark brown, beige and white.

PLASTIC DOMED 5 GROSS PACK			
Osborne No.	WPLDBB-5	WPLDBB-5	WPLDBW-5
Description	Beige Plastic Domed	Dark Brown Plastic Domed	White Plastic Domed

* Also available in 1 and 25 Gross Boxes.



PLASTIC SUPER HOOK, PATENTED

Applicable on : reversible cushions, nonreversible cushions, tight seats, chair backs, bolsters, hassocks, etc. Fast installation, low cost, perfect tufting depth every time. Knots won't come untied due to operator fatigue. Loops and super clips are pre-measured, ready-to-use.

1. BUTTON SITS FLAT

Tapered shank allow button to sit flat.

2. INSTALLS FASTER

Exclusive slope design guides loop into hook with one pass. Cuts production time, cuts costs.

3. WON'T RIDE UP

Curved double snubbers keep loop from riding up into lock channels.

4. NO FRAYING

Smooth edges will not fray twine.

5. EXTRA HOLDING POWER

Ribbed nylon exerts additional pressure to hold finished buttons together.

6. IT'S STRONGER

Extra high impact nylon, solid one-piece, for added strength.

7. HOLDS TIGHTER

Grooved rim helps hold material and shell tight to the collet. Great for vinyl. Puts the stop on popoffs.

8. WON'T WORK LOOSE

Double lock channels further restrict loop from ever ridding up.

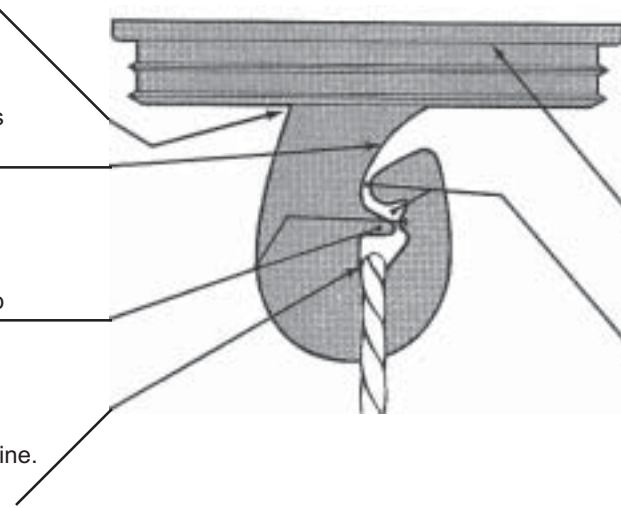

PLASTIC SUPERHOOK 5 GROSS BOX(also in 1, 25 & 50 gr. box).				
Osborne No.	WPSH22-5	WPSH30-5	WPSH36-5	WPSH45-5
Size	22	30	36	45



POLY WASHER FOR SUPER HOOK



Made of fibre. Ideal washer for super hook buttons. It has one inch diameter. Great holding power. Available in 1, 25 and 50 gross box.

POLY WASHER FOR SUPERHOOK		
Osborne No.	WWAP138-5	WWAP138-50
Description	Poly washer for superhook	

UNASSEMBLED NAIL OR TACK MOLD

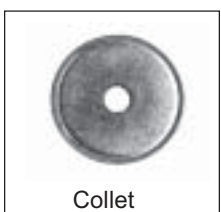

ADVANTAGES: Costs, less than a pre-assembled nail, used with special tacks or nails. Your supply the nail or tack of your choice.

COVERING OPERATION: Collet (button back) is placed in die. Nail (or tack) is inserted through hole in collect. Cardboard Wad is place on top of the nail. Covering is then completed in the usual manner.

COLLETS 5 GROSS BOX (ALSO AVAILABLE IN 1, 25 & 50 GR. BOX).					
Osborne No.	WCO22-5	WCO30-5	WCO36-5	WCO40-5	WCO45-5
Size	22	30	36	40	45

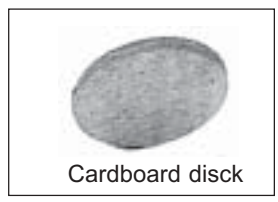

Please specify quantity when ordering.

CARDBOARD DISCK 5 GROSS BOX(ALSO AVAILABLE IN 1,25 & 50 GR. BOX).				
Osborne No.	WCW22-5	WCW30-5	WCW36-5	WCW40-5
Size	22	30	36	40



1.- Place material on the wood block. Lay cutter on material. Pull on handle to cut button covers. Fold or stack material to cut more pieces at the time.



2.- Turn top of the two piece die . Place the cut material on the die, then center the shell on top of the material as shown in the picture.



3.- Holding the die use the wood dowel to push the shell in.



4.-Lay wire eye on the bottom die with the loop facing down.



5.- Place the two piece die together on the machine . Lock in the bottom piece die with the Allen wrench key provided.



6.- Firmly press on handle to close the button.



7.- A secure button is completed



COMBOS

The COMPLETE BUTTON consists in a SHELL and any kind and type of back like Wire Eye, etc. When you are ordering make sure you state whether you want the complete button or just one part of it. The complete button number starts with WCM then the size of the button, then the letter of the backs (like WE for wire eye or NDN for no dent nail, etc.), then the type of shell (like SS for soft shell, RR for Rust Resistant, etc.) and finally the quantity pack (1GR for one gross box or 5GR for 5 gross box).

WCM= COMBO
 WE= WIRE EYE
 PR=PRONG
 TN=THREADED NAIL
 ND=NO DENT NAIL
 PSR=PLASTIC SNAP RING
 SS=BLACK OXIDE SOFT SHELL
 RS=REGULAR SHELL
 RR=RUST RESISTENT
 SH=SUPER HOOK
 PSR=PLASTIC SNAP RING
 1GR=ONE GROSS BOX
 5GR=FIVE GROSS BOX
 25GR=TWENTY FIVE GR.BX
 50GR=FIFTY GROSS BOX

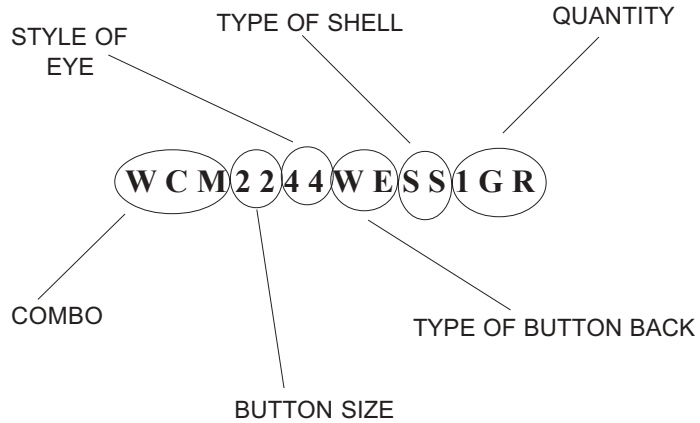

WIRE EYE No. 44 WITH SOFT SHELLS

No. 44 WIRE EYE WITH BLACK OXIDE SOFT SHELL 5 GR. BOX (ALSO AVAILABLE IN 1 GR. BOX).

Osborne No.	WCM2244WESS5GR	WCM2444WESS5GR	WCM3044WESS5GR	WCM3644WESS5GR
Size	22	24	30	36
	40	45	50	60
Osborne No.	WCM4044WESS5GR	WCM4544WESS5GR	WCM5044WESS5GR	WCM6044WESS5GR

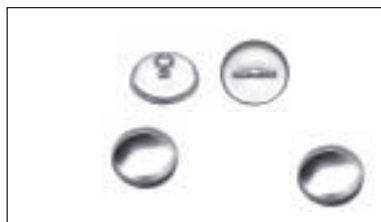

WIRE EYE No. 9 WITH SOFT SHELLS

No. 9 WIRE EYE WITH BLACK OXIDE SOFT SHELL 5 GR. BOX (ALSO AVAILABLE IN 1 GROSS BOX).

Osborne No.	WCM229WESS5GR	WCM249WESS5GR	WCM309WESS5GR	WCM369WESS5GR
Size	22	24	30	36
	40	45	50	60
Osborne No.	WCM409WESS5GR	WCM459WESS5GR	WCM509WESS5GR	WCM609WESS5GR



COMBOS

PRONG WITH BLACK OXIDE SOFT SHELL 5 GR. BOX (ALSO AVAILABLE IN 1 GR. BOX).					
Osborne No.	WCM22112PRSS5GR	WCM222PRSS5GR	WCM22212PRSS5GR	WCM242PRSS5GR	WCM24212PRSS5GR
Size	22			24	
	30				36
Osborne No.	WCM30112PRSS5GR	WCM302PRSS5GR	WCM30212PRSS5GR	WCM303PRSS5GR	WCM36112PRSS5GR
Size	36		40		45
Osborne No.	WCM362PRSS5GR	WCM36212WESS5GR	WCM40112PRSS5GR	WCM402PRSS5GR	WCM452PRSS5GR

THREADED NAILS WITH SOFT SHELL 5 GR. BOX (ALSO AVAILABLE IN ONE GROSS BOX).					
Osborne No.	WCM2278TNSS5GR	WCM22112TNSS5GR	WCM222TNSS5GR	WCM2478TN5GR	WCM3078TNSS5GR
Size	22			24	30
	30		36		
Osborne No.	WCM30112TNSS5GR	WCM302TNSS5GR	WCM3678TNSS5GR	WCM36112TNSS5GR	WCM362TNSS5GR

NO DENT NAILS WITH SOFT SHELL 5 GR. BOX (ALSO AVAILABLE IN ONE GROSS BOX).					
Osborne No.	WCM2234NDSS5GR	WCM2234NDSS5GR	WCM221NDSS5GR	WCM3034NDSS5GR	WCM301NDSS5GR
Size	22			30	
	30		36		45
Osborne No.	WCM30114NDSS5GR	WCM30112NDSS5GR	WCM3634NDSS5GR	WCM361NDSS5GR	WCM451NDSS5GR



PLASTIC SUPERHOOK WITH SOFT SHELLS

PLASTIC SUPER HOOK WITH SOFT SHELL 5 GR. BOX (ALSO AVAILABLE IN ONE GROSS BOX).				
Osborne No.	WCM22SHSS5GR	WCM30SHSS5GR	WCM36SHSS5GR	WCM45SHSS5GR
Size	22	30	36	45



PLASTIC SNAP RINGS WITH SOFT SHELLS

PLASTIC SNAP RINGS WITH SOFT SHELL 5 GROSS BOX (ALSO AVAILABLE IN ONE GROSS BOX).		
Osborne No.	WCM30PSRSS5GR	WCM36PSRSS5GR
Size	30	36

SAME BUTTON SIZE AND QUANTITIES ALSO AVAILABLE WITH ALUMINUM SHELLS, REGULAR SHELLS AND RUST RESISTENT SHELLS. PLEASE SPECIFY TYPE AND SIZE WHEN ORDERING.



TUFTING NEEDLE & CLASPS

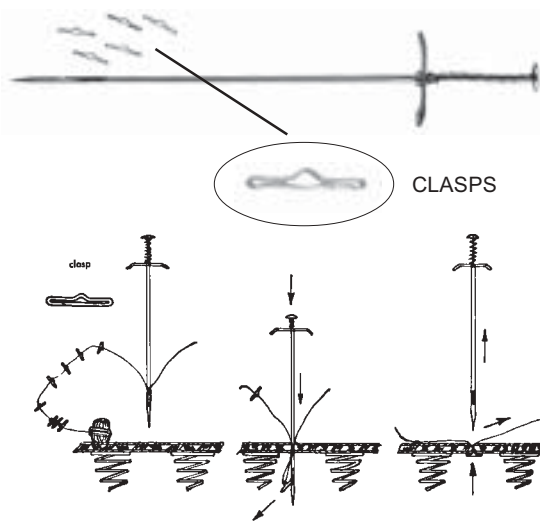

Osborne No. 417 & 418

THE VERY BEST. Does not catch when it is withdrawn. After threading button, end of needle is loaded with clasps. As needle reaches maximum depth, clasp is rejected. Saves time and labor. No need to remove the outside back of piece being tufted. A splendid tool to the true craftsperson.

Working Process:

- 1.- At the start assemble on the thread the corresponding quantity of clasps for the required number of stitches. Insert clasp with thread in the hollow of the needle.
- 2.- Push needle (with inserted clasps and thread) through upholstery fabric, press head of needle. Clasp with thread will be ejected.
- 3.- Pull needle out and tighten thread, clasp will be anchored inside.

Instructions are included with the tool.

417

418

Overall length (inch)	Weight ea (oz)	UPC No.
12	3	64386

Each per box	Weight ea (oz)	UPC No.
500	10	14388

HEAVY-DUTY TUFTING NEEDLE



Osborne No. 415

Here is a 6 Gauge or 0.198 inch diameter tufting needle. Just the thing for those heavy-duty jobs that are a little too much for our popular No. 417 Tufting Needle. Furnished with complete instructions. Use clasps No. 418.

Overall length (inch)	Weight ea (oz)	UPC No.
12	3	64380

MATTRESS BUTTON TUFTER



Osborne No. 414

Thread button on cord, cut to length. Push needle through mattress until cord ends come through. Pull out needle. Repeat on all buttons. Then turn over mattress and tie.

SIZE	Overall length (inch)	Gauge	Weight ea (oz)	UPC No.
12	12	11	1	64372
14	14	11	1	64374

TUFTING NEEDLE AND CLASPS

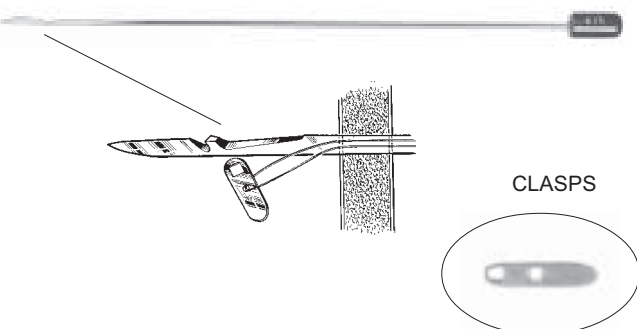

Osborne No. 613 & 614

Furniture button tufter comes with two dozen clips free. Osborne quality needle. Thread twine in round hole in clip, hook square hole on needle and, push then withdraw needle. Directions included.

Overall length (inch)	Gauge	Weight ea (oz)	UPC No.
12	10	2	64390

**No.613
NEEDLE**

Each per bag	Weight ea (oz)	UPC No.
144	5	14392

No. 614 CLASPS ONLY



NYLON TUFTING TWINE



TUBE

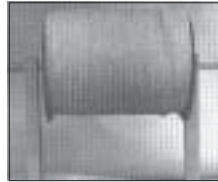

REEL

Osborne No. 4700

Made of superior quality white nylon. This twine has high tensile strength required for holding buttons in place. Available in three different presentations.

Osborne No.	Description	UPC No.
4700-R	50 End Reel of 40 lbs.	78304
4700-T1/2	1/2 lbs. tube	78308
4700-T2	2 lbs. tube	78312

LOOP NEEDLE



Osborne No. 615

Loop needle with a 1/2" slot to hold pre-tied loops. Also used for hand tufting with pretied nylon loops. Available in 11" and 17". Please specify length when ordering.

Overall length (inches)	Slot (inches)	Weight ea (oz)	UPC No.
11	1/2	2	14394
17	1/2	3	14396

"T" HANDLE TUFTING TOOL



Osborne No. 408

High quality osborne tufting tool. Made of hardened steel with rubber handle. Used for pulling loops through or up.

Overall length (inch)	Weight ea (oz)	UPC No.
10 1/2	3	64342

PRONG BUTTON TUFTER



Osborne No. 419

The Osborne No. 419 Prong Button Tufter accepts any length of prong 22 to 45 size of button. Tool is withdrawn after piercing fabric leaving the prongs extended through the fabric. This keeps the prongs from spreading while being put through the padding.

Overall length (inch)	Weight ea (oz)	UPC No.
5 1/2	2	64398



CANING CHISEL



Osborne No. 405

High quality tool. Hardened and tempered steel. Available in two sizes to fit groove size. Has a translucent plastic handle.

Osborne No.	Blade length (inches)	Blade width (inches)	Overall Length (inches)	Weight ea (oz)	UPC No.
405 1/8	4	1/8	8	3	53222
405 3/16	4	3/16	8	3	53224

CANING NEEDLE

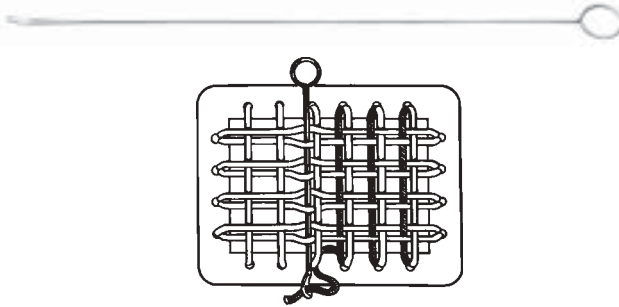

Osborne No. 407

Makes weaving in the strands faster and easier. Snake the needle through the strands, thread the eye and pull needle across the frame.

Overall length (inches)	Size of eye (inches)	Weight ea (oz)	UPC No.
21	1/8 x 3/32	1	64338

Weaving strands with the Osborne No. 407 Needle

CANING TOOL



Osborne No. 406

This Caning Tool can be used to move individual or multiple canes during any stage of the caning process by hooking one or both pins behind the cane and pulling it into position. This tool makes caning easier with less repetitive motion and lighter finger load.



Length (inches)	Weight ea (oz)	UPC No.
5 1/4	1	64336

BASKET WEAVING TOOL WITH EYE



Osborne No. 423

Similar to our No. 407 Caning needle, but shorter and with a handle for work in the more confining space of basket weaving.

Overall length (inches)	Size of eye (inches)	Weight ea (oz)	UPC No.
7 3/4	1/8 x 3/32	1	64339

BASKET WEAVING TOOL



Osborne No. 424-S

Stainless steel straight blade. Round polished hardwood handle. Ideal for working in water.

Blade length (inches)	Overall length (inches)	Weight ea (oz)	UPC No.
3 3/8	7	1	64337



Osborne No. 424-B

Stainless steel bent blade. Round polished hardwood handle. Ideal for working in water.

Blade length (inches)	Overall length (inches)	Weight ea (oz)	UPC No.
3 1/8	7	1	64335



HAND VENTILATOR SETTER



Size	Length (inches)	Width (inches)	Weight ea (oz)	UPC No.
3/4	4	1	14	64402
1	4	1 1/2	20	64404

Osborne No. 621-3/4

For setting 3/4" Ventilators.

- 1.- Punch 9/16 hole in material (Use Osborne No. 149 -9/16" punch or on Vinyl, use No. 149 7/16 punch).
- 2.- Lay ventilator neck up on base, place material over ventilator, now slip ventilator ring on bow side up. A few event taps with an Osborne Rawhide Mallet No. 196 will set ventilators.

Osborne No. 621-1

For setting 1" Ventilators.

- 1.- Punch 3/4 hole in material(Use Osborne No. 149 -3/4" punch or on Vinyl, Use No. 149-5/8 punch).
- 2.- Lay ventilator neck up on base, place material over ventilator, now slip ventilator ring on bow side up. A few event taps with an Osborne Rawhide Mallet No. 196 will set ventilators.

VENTILATORS



Osborne No. V-1 3/4

Brass Plain rim ventilators used with our 621-3/4. Packed one gross.

Osborne No. V-1 1

Brass Plain rim ventilators used with our 621-1. Packed one gross.

Size No.	Diameter of hole when set (inches)	Weight per gross (lbs)	(oz)	UPC No.
3/4	9/16	1	0	14412
1	3/4	1	4	14414

VENTILATOR PUNCH



Osborne No. 622

Hardened and tempered steel. High quality. Used to punch ventilator holes illustrated in pattern.

Overall Length(inch)	Holes diameter(inch)	Weight ea (oz)	UPC No.
5 1/4	3/32	10	02198

MARKING CHALK



Osborne No. 88

Clay based and thus it is much easier to erase. Other chalks that are not clay based will leave a grease on cottons and other fabrics. Also works on glass vinyl that other chalks don't. Due to the shape of this chalk a sharp marking edge is maintained.

Contains:

- 8 white chalks
- 2 yellow chalks
- 1 red chalk
- 1 blue chalk

Weight ea (oz)	UPC No.
6	14003



GENUINE BONE FOLDER, TRADITIONAL

Osborne No. 464

Highly polished genuine cattle bone folder for pasting and folding. Also for burnishing Latrone sheets, lettering, gold leaf etc. Ideal size for best results.



Length (inches)	Weight ea (oz)	UPC No.
6 1/4	1	67478

GENUINE BONE FOLDER, STRAIGHT

Osborne No. 727A

Straight real high polished cattle bone folder for pasting and folding. Also for burnishing Latrone sheets, lettering, gold leaf, etc. Available in three different sizes.



Size	Length (cm) & (inch)	Weight (onz)	UPC No.
15	15 - 6	1	14664
18	18 - 7-1/8	2	14666
20	20 - 7-15/16	2	14668

SYNTHETIC BONE FOLDER

Osborne No. 465

This bone folder is similar to our No. 464 Bone Folder except that it is made of polished nylon.



Length (inches)	Weight ea (oz)	UPC No.
6 1/4	1	67484

BENT BONE FOLDER

Osborne No. 727

Bent real high polished cattle bone folder for pasting and folding. Also for burnishing Latrone sheets, lettering, gold leaf, etc.



Size	Length (cm) & (inch)	Weight (onz)	UPC No.
15	15 - 6	1	14658
18	18 - 7-1/8	2	14660
20	20 - 7-15/16	2	14662



AUTO TRIMMER'S AND UPHOLSTERER'S COMBINATION KNIFE



Osborne No. 1020

Made of finest steel with both hook and pointed blade. Used for ripping seams. Cuts auto carpeting, vinyl, plastic and rubber. Beechwood handle contoured to fit hand. A handy professional tool.

Length of blade (inches)	Weight ea (oz)	UPC No.
2 7/8	4	60146

SHARPENING STONE



Osborne No. 1021

Specially contoured stone to sharpen the hook as well as the other parts of the Osborne No. 1020 knife. This quality stone can be used to sharpen other Osborne knives.

Overall length (inches)	Diameter (inches)	Weight ea (oz)	UPC No.
6	3/4	2	64512

HAWKBILL KNIFE



Osborne No. 420

This hawkbill knife is made of finest cutlery steel. Varnished hardwood handle.

Length of blade (inches)	Weight ea (oz)	UPC No.
3	2	60100

THE SKIFE



Osborne No. 925

Makes a remarkably easy job of skiving leather and other materials. Increases both speed and accuracy. This essential tool is fitted with a special razor blade. Ideal for restoration work. Extra blades available. Weight each 2 oz. UPC No. 60182.

Osborne No. 925-D 20-blade safety dispenser. UPC No. 04113. **Osborne No. 925-100** Bulk pack of 100 blades. UPC No. 10183.





SQUARE POINT KNIFE

Osborne No. 76 1/2

Trimmer's and upholsterer's knife. White handle. Steel blade.



Length of blade (inches)	Width of blade (inches)	Weight ea (oz)	UPC No.
3 7/8	5/8	2	60046

SQUARE POINT KNIFE - With safety guard

Osborne No. 77

Same as Osborne No. 76 1/2, but furnished with steel safety guard.



Length of blade (inches)	Width of blade (inches)	Weight ea (oz)	UPC No.
3 7/8	5/8	2	60050

SHARP POINT KNIFE

Osborne No. 79 1/2

White hardwood handle, sharp point knife. A popular knife in the upholstery and trimming business. Steel blade.



Length of blade (inches)	Width of blade (inches)	Weight ea (oz)	UPC No.
3 3/4	3/4	2	60060

BEVEL POINT SKIVING KNIFE

Osborne No. 479

Used for skiving and edge trimming on leather and similar materials. Plated ferrule. Lacquered hardwood handle.



Length of blade (inches)	Weight ea (oz)	UPC No.
3	2	60112

SHEATH - For Osborne knives

Osborne No. 72

A sturdy leather sheath for our industrial knives. Slits fit on belt. Stitched edges reinforced with six rivets.



Length overall (inches)	Length of pocket (inches)	Width (inches)	Weight ea (oz)	UPC No.
10	5 1/4	2	3	60184



HEAVY DUTY SCRATCHAWL



Osborne No. 4

Made in four sizes for your convenience. Best quality steel blades with rugged amber translucent plastic handles.

Size No.	Blade length (inches)	Weight ea (oz)	UPC No.
1	2 1/2	1	62012
2	3 1/2	2	62014
3	4 1/2	3	62016
4	5 1/2	4	62018

SCRATCHAWL



Osborne No. 478

Sharp pointed. Tempered blade for piercing leather, sewing and a variety of uses. Hardwood handle.

Blade length (inches)	Overall length (inches)	Weight ea (oz)	UPC No.
2	3 7/8	1	62022

SCRATCHAWL

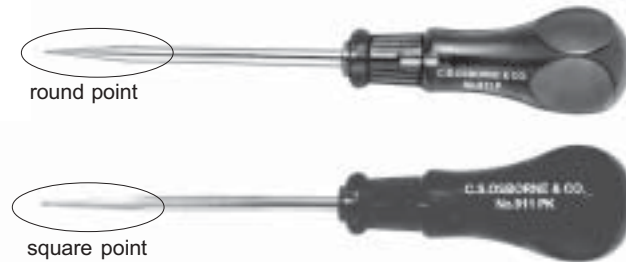

round point

square point

Osborne No. 911-P

Sharp round pointed. Plastic handle. Hardened steel blade.

Blade length (inch) & (mm)	Weight ea (oz)	UPC No.
4 & 100	3	65146

Osborne No. 911-PK

Same as above but with square point. UPC. No. 65148

BADMINTON AWL



Osborne No. T-10

Sharp point. Hardwood handle.

Blade length (inches)	Overall length (inches)	Weight ea (oz)	UPC No.
1 1/4	5	1	62032

TENNIS AWL



Osborne No. T-11

Blunt point prevents scratching the leather when aligning, etc. Hardwood handle.

Blade length (inches)	Overall length (inches)	Weight ea (oz)	UPC No.
2 1/2	6 1/4	1	62042

ALL PURPOSE AWL



Osborne No. 18

The bent awl is a varied-purpose tool. Great for hard to reach places in upholstery work. Can be used to remove small staples in grooves. Tempered end.

Blade length (inches)	Overall length (inches)	Weight ea (oz)	UPC No.
5 1/2	9 1/2	4 1/2	62052



AUTOMATIC AWL

Osborne No. 413

An excellent tool for sewing leather, canvas and similar materials. The awl carries a spool of waxed polyester black thread on the handle. Hollow handle holds extra curved needle and wrench. Directions furnished with each awl explaining how automatic awl lock stitch can be effected in repair work. Furnished with one straight (Osborne No. 413N 8) and one curved diamond point (Osborne No. 413N 6) needle.



Osborne No. 413LT
1 lb. tube of thread
740 yards



Osborne No. 413ST
1/4 lb. tube of thread
185 yards



Osborne No. 413R
reel of thread
12½ yards

Osborne No.	Description	Weight ea (oz)	UPC No.
413	Automatic awl	3	62142

Replacement parts		
Osborne No.	Description	UPC No.
413N 5	Short straight needle	62192
413N 6	Curved needle	62194
413N 8	Coarse straight needle	62196
413N 8C	#8 Curved needle	62198
413R B	Reels of black thread	62182
413R BR	Reels of brown thread	62184
413R W	Reels of white thread	62186
413ST B	Black thread 1/4 lb. tube	12162
413ST BR	Brown thread 1/4 lb. tube	12164
413ST W	White thread 1/4 lb. tube	12166
413LT B	Black thread 1 lb. tube	62152
413LT BR	Brown thread 1 lb. tube	62154
413LT W	White thread 1 lb. tube	62156

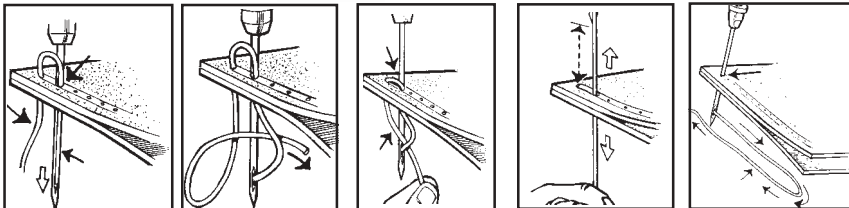

TUCKING TOOL

Osborne No. 747 RIGID

For tucking headlining and upholstery around windows and above doors and other hard to reach places. A sturdy tough tool with a slightly curved blade that has finished edges and rounded corners. Comfortable wood handle with eyelet hole through one end.



Length of blade (inches)	Overall length (inches)	Weight ea (oz)	UPC No.
2-5/8	7-1/2	4	64704

Osborne No. 746 FLEXIBLE

Same as above but with flexible spring steel blade. A very popular tool.
UPC No. 64702.



PALM AWL HAFT



Osborne No. 142

Designed to fit in the palm of your hand. Comes with chuck and wrench. Holds all Osborne awls shown below. Weighs 1-1/2 ounces. UPC No. 62210.

PEG AWL HAFT



Osborne No. 143

A widely used type of awl haft. Comes with chuck and wrench to permit easy changing of blades. Leather tipped to prevent splintering when hammered. Holds all Osborne awls shown below. Weighs 2 ounces. UPC No. 62212.

SHOE AWL HAFT



Osborne No. 144

Clear lacquer finish, brass ferrule. Holds awls No. 43, 44, 32 and needle No. 504-4 when they are forced into wood. Please specify when ordering, with awl inserted or by itself. Weighs one ounce. UPC No. 62222.

SEWING AWL HAFT



Osborne No. 145

A popular sewing awl haft. Widely used by shoemakers. Knobbed end permits easy grasp and prevents slipping. Also made for wrapping thread. Made of hard maple. Varnished. Comes with chuck and wrench. Holds all Osborne awls shown below. Weighs two ounces. UPC No. 62224.

CURVED SEWING AWLS



Finest quality.

Osborne No. 31

Size (inches)	2 1/2	3	3 1/2
UPC No.	62082	62084	62086

STABBING AWLS, ROUND POINT



Finest and toughest steel.

Osborne No. 32

Size (inches)	2 1/2	3
UPC No.	62092	62094

SADDLERS' HARNESS AWL

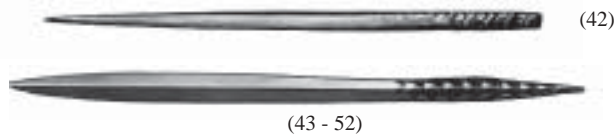

Finest quality. Special thin sizes.

Osborne No.	42	43	44	45	46	47	48	49	50	52
Size (inches)	1 1/2	1 3/4	2	2 1/4	2 1/2	2 5/8	2 3/4	2 7/8	3	3 1/4
UPC No.	62100	62102	62104	62106	62108	62110	62112	62114	62116	62118

SADDLERS' STITCHING AWL

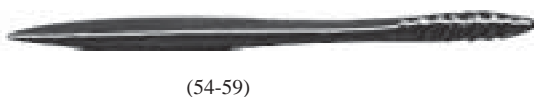

Finest quality. Hand ground.

Osborne No.	54	56	57	58	59
Size (inches)	2	2 1/4	2 1/2	2 3/4	3
UPC No.	62120	62122	62124	62126	62128



HOG RING PLIERS WITH VINYL HANDLES



OPENING SPRING



NO SPRING

Osborne No. 1440
 Nine different styles with straight or angled handles, comes with opening springs, closing springs and no springs. Please specify style. Grooves are the proper depth. Made of forged steel and vinyl handles. Each one weighs eight ounces. Works with Osborne hog rings **No.1442 and 1443. Please specify style when ordering.**

1440-A	Straight handles 6-3/4" long
1440-B	Handles bent at 135 degrees angle to jaw
1440-C	Handles bent to reach difficult spots
(Jaws and handles are aligned)	

Osborne No.	Type	UPC No.
1440-A	No spring	54132
1440-B	No spring	54138
1440-C	No spring	54144
Springs only also available		
Replacement Springs		
1440-SC	Closing spring	54152
1440-SO	Opening spring	54154



CLOSING SPRING



23S-M

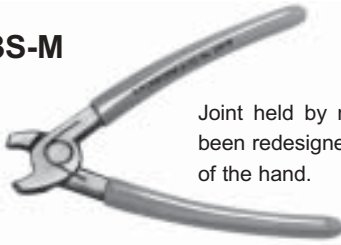

Joint held by rivet. Handles have been redesigned to fit the palm of the hand.



23P-M



23-M

HOG RING PLIERS WITH BOW HANDLES

Same as our popular 1440's but with open space between the handles. Made of durable, hot forged and tempered steel, Improved Hog Ring Grooves. Different styles available. Overall length is 7 -1/4 inches.

Osborne No.	Description	Weight(onz)	UPC No.
STRAIGHT TYPE			
23-M	Hog ring pliers without spring	9	54182
23P-M	Hog ring pliers with closing spring		54186
23S-M	Hog ring pliers with opening spring		54184
BENT TYPE			
2350-M	Hog ring pliers without spring	9	59194
2350TP-M	Hog ring pliers closing spring		54202
2350TS-M	Hog ring pliers with opening spring		54204

2350TS-M

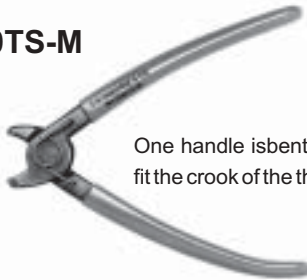

One handle is bent slightly for a comfortable fit the crook of the thumb. Joint held by a rivet.



2350TP-M



2350-M

STRAIGHT TYPE			
23T-M	Hog ring pliers without spring	9	54188
23TP-M	Hog ring pliers closing spring		54192
23TS-M	Hog ring pliers with opening spring		54190
BENT TYPE			
2360T-M	Hog ring pliers without spring	9	54206
2360TP-M	Hog ring pliers closing spring		54208
2360TS-M	Hog ring pliers with opening spring		54207

Springs-only, also available separately

23TS-M

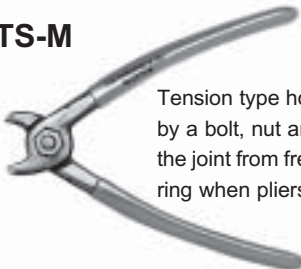

Tension type hog ring pliers. The joint is held by a bolt, nut and tension washer; this keeps the joint from freezing and helps hold the hog ring when pliers is laid down.



23TP-M



23T-M



2360TS-M



2360TP-M

2360T-M



Tension type hog ring pliers. The joint is held by a bolt, nut and tension washer. This keeps the joint from freezing and helps hold the hog ring when plier is laid down.



HOG RINGS

Osborne No. 1442
To be used with Osborne No. 1440 , 23, 23T, 2350N Hog Ring Pliers.

SHARP POINTS



OPEN



CLOSED

Polished . 3/4 " rings.

Osborne No.	Description	Quantity per box (aprox.)	UPC No.
1442-5	Weight 5 lbs/box	2400	14592
1442-25	Weight 25 lbs/box	12000	14594

Osborne No. 1444SS-5
Same as above but **Stainless Steel**. UPC No. 14600. Box of 5 lbs. available. Sharp points.

HOG RINGS

Osborne No. 1443
To be used with Osborne No. 1440 , 23, 23T, 2350N Hog Ring Pliers.

BLUNT POINTS



OPEN



CLOSED

Polished . 3/4 " rings.

Osborne No.	Description	Quantity per box (aprox.)	UPC No.
1443-5	Weight 5 lbs/box	2400	14596
1443-25	Weight 25 lbs/box	12000	14598

HOG RING PLIERS

Osborne No. 773-HRP
Hardened and tempered. Forged steel. Vinyl handles. Works with our new 773-K millimeter hog rings. Ideal for closing around a smaller area. Can be used on bungee cord.



Length (mm) & (inches)	Weight ea (oz)	UPC No.
180mm - 7 1/8	8	64794

HOG RINGS

Osborne No. 773-K
To be used with our 773-HRP Hog Ring Pliers. Available in 5/8" with blunt and sharp points , and 7/8" with sharp points only. Specify when ordering.



Osborne No.	Description	Quantity per box	UPC No.
773-KB 20	5/8" Blunt hog rings	1000	64801
773-KS 20	5/8" Sharp hog rings	1000	64797
773-K 25	7/8" Sharp hog rings	1000	64799



HEADREST RELEASE KEY SET



Osborne No. K-752

Set of 4 Headrest Release Keys No. 752's. Perfect for auto trim work.

1 each of following sizes Osborne No. 752 Headrest release keys.						Weight per set (lbs)	UPC No.
K-752	Sizes (inches)	1/4	3/8	1/2	5/8		
						4 1/2	14722

DOOR HANDLE CLIP REMOVER



Osborne No. 758

High quality. Perfect for auto trim work. Plated. An industry standard.

Overall length (inches)	Weight ea (oz)	UPC No.
7	4	64764

MOULDING RELEASE KEY



Osborne No. 757

High quality. Perfect for auto trim work. Plated. An industry standard.

Overall length (inches)	Weight ea (oz)	UPC No.
7	4	64762

TRIM PAD REMOVER



Osborne No. 760

High quality. Perfect for auto trim work. Plated. An industry standard.

Overall length (inches)	Weight ea (oz)	UPC No.
8-1/2	4	64766

AUTO WINDSHIELD KNIFE



Osborne No. 801

Unique double blade action helps cut out urethane around windshields. Plastic amber handle.

Osborne No.	Length (inches)	Width (inches)	Weight (onzes)	UPC No.
801-L	5-1/2	3/16	4	60162



GLUE STICKS

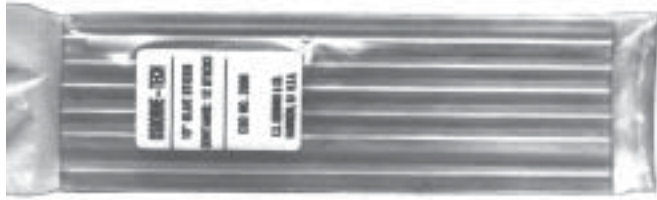

Osborne No. 2000

Hot melt adhesive for use with glue gun. Ideal for Upholstery and restoration work. Size 1/2" diameter by 10" long. Each one weighs 4 ounces.

Packed 12 sticks to a box. UPC No. 64636.

GLUE STICKS - BULK



Osborne No. 2003

Same type of glue sticks as above bulk packed 22 lbs. per box.

Each box contains approximately 375 glue sticks.

Box measures 22" x 11" x 4". Weighs 22 lbs.

UPC No. 64638.

NEEDLE NOSE LACING PLIERS



Osborne No. 103 1/2

Lacing pliers, forged steel. Single joint, polished jaws, black handle. Slightly serrated jaw.

Length (inches)	Weight ea (oz)	UPC No.
5 1/2	3	54022

VINYL ROOF, CARPET AND VENEER ROLLER



Osborne No. 399

Used to roll on vinyl roofs, gets all the air pockets out and used on interior carpeting to smooth it out. This tool can also be used for Veneer work in furniture. Available in 2 sizes. Round edge, single side design to get close to walls. Ball bearing race. Available in two handle sizes.

Size No.	Overall length (inches)	Weight ea (lbs)	UPC No.
399-S	9-1/2	2-1/4	14304
399-L	12	2-1/2	14302

SQUARE EDGE SEAM ROLLER



Osborne No. 499

Same as above except squared on both sides. Used to roll on linoleum seam work, asphalt tile, and coving work. Available in two handle sizes.

Size No.	Overall length (inches)	Weight ea (lbs)	UPC No.
499-S	9-1/2	2-1/4	64798
499-L	12	2-1/2	64796



BENT TRIMMERS

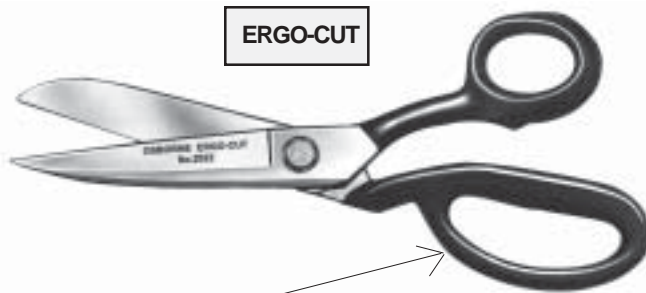

Enlarged Lower Ring for Added Comfort.

Osborne No. 2022

Premium heavy duty shear with black cushion grip handles designed to cut multiple layers of fabric simultaneously. Hardened for long life. The edges come standard with a knife edge for easier fabric cutting action. Pivot is a wave washer supported power lock screw that will not loosen during service. Corrosion resistant chrome over nickel plated industrial finish. Slices easily through carpet, canvas, rubber and multi-layers of material.

Overall Length (inches)	Length of cut(inches)	Weight each (onzes)	UPC No.
11	4-3/4	20	60526

ERGO DESIGNED SHEARS



Enlarged Lower Ring for Added Comfort.

Osborne No. 2020

Premium large ring industrial quality bent trimmer. The ring is designed to fit a complete hand thus allowing the hand to function in a normal manner. The ring is soft coated with black coating for added comfort. Knife edge for easier fabric cutting action. Pivot is a wave washer supported power lock screw that will not loosen during service. Corrosion resistant chrome over nickel plated polish finish. Ideal for cutting synthetics fibers.

Overall Length (inches)	Length of cut(inches)	Weight each (onzes)	UPC No.
10	4-1/2	15	60518

ERGO DESIGNED SHEARS

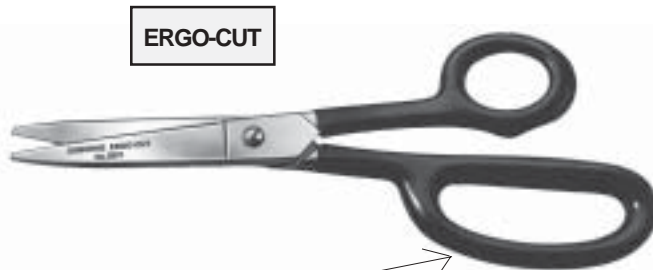

Enlarged Lower Ring for Added Comfort.

Osborne No. 2021

High leverage shears that comes with a large soft coated black ring to fit additional fingers for added cutting force. The tool is standard with a knife edge and serrated blade for gripping leather. Hardened for extra long life. Corrosion resistant chrome over nickel plated polish finish. Pivot is standard with non loosening power lock screw supported by spring steel split washer.

Overall Length (inches)	Length of cut(inches)	Weight each (onzes)	UPC No.
9	4-3/4	8	60522

MULTI-PURPOSE SHEARS



Enlarged Lower Ring for Added Comfort.

Osborne No. 2023

Large ring soft handled ergonomic bent trimmer. Less strain on wrist and hand. The tool has stainless stamped blades with a heavy blade cross section, reinforced pivot, and compound cutting edge for low cutting force when cutting fabrics. Hardened for extra long life. Excellent for glove use on wet applications. May be used right or left hand. Blue handles.

Overall Length (inches)	Length of cut(inches)	Weight each (onzes)	UPC No.
9	3-1/4	5	60528



WISS BENT TRIMMER SHEAR



No. 20-S and 22

High quality. Each blade forged of one piece. Inlaid blades. Black handles. Polished blades. A very popular shear for upholstery work.

Osborne No.	Overall Length (inches)	Length of cut (inches)	Weight (onzes)	UPC No.
20-S	10	4-3/4	12	60512
22	12	6-1/8	18	60532

WISS BENT TRIMMER SHEAR



No. 27, 28 and 29-S

High quality. Each blade forged of one piece. Inlaid blades. Black handles. Nickel plated blades. Similar to above shears but shorter in length and cut. Also lighter.

No.	Overall Length (inches)	Length of cut (inches)	Weight (onzes)	UPC No.
27	7	3-1/8	4	60552
28	8	3-3/4	6	60562
29-S	9	4	8	60582

WISS BENT TRIMMER SHEAR (Left Hand)



No. 20LH

High quality. Each blade forged of one piece. Inlaid blades. Black handles. Nickel plated blades. The perfect shears for the left hand upholsterer.

Overall Length (inches)	Length of cut (inches)	Weight (onzes)	UPC No.
10	4 - 3/4	13	60520

WISS BENT TRIMMER SHEAR (Knife Edged)



No. 1225 and 1226

High quality. Each blade forged of one piece. Inlaid blades. Black handles. Polished & nickel plated blades. Patented set-easy pivot. Similar to the No. 20-S and 22 but heavier.

No.	Overall Length (inches)	Length of cut (inches)	Weight (onzes)	UPC No.
1225	10	4-7/8	14	60542
1226	12	6-1/8	20	60544

WISS UPHOLSTERY & CARPET SHEAR (raised blade)



No. 20W and 22W

High quality. Each blade forged of one piece. Inlaid blades. Black handles. Polished blades. Patented set-easy pivot. Ideal for carpet work. It has a raised blade.

No.	Overall Length (inches)	Length of cut (inches)	Weight (onzes)	UPC No.
20W	10	4 - 3/4	14	60524
22W	12	6 - 1/8	20	60536



WISS STRAIGHT TRIMMERS



No. 30, 36-S and 38-S

High quality. Each blade forged of one piece. Inlaid blades. Black handles. Polished blades.

No.	Overall Length (inches)	Length of cut (inches)	Weight (onzes)	UPC No.
30	10	4 - 7/8	12	60592
36	6	2 - 5/8	3	60602
38	8	3 - 3/4	3	60612

WISS PINKING SHEARS



No. AA

Hot drop-forged, professional industrial model, extra large teeth. Nickel plated blades. Black handles.

Overall Length (inches)	Length of cut (inches)	Weight (onzes)	UPC No.
10 - 5/8	3 - 7/8	13	10662

WISS PINKING SHEARS



No. CB-9

Hot drop-forged, professional industrial model, extra large teeth. Nickel plated blades. Black handles. Less length and length of cut that above shears.

Overall Length (inches)	Length of cut (inches)	Weight (onzes)	UPC No.
9	3 - 1/4	8	10670

WISS AUTO BODY SHEARS



No. 1-DS

Hot drop-forged. Inlaid blades. Nickel plated blades.

Overall Length (inches)	Length of cut (inches)	Weight (onzes)	UPC No.
8	3	7	60712

WISS RUG SHEARS



No. RS-1

Hot drop-forged. Double sharp points. Black offset handles solid steel.

Overall Length (inches)	Length of cut (inches)	Weight (onzes)	UPC No.
7 - 1/2	2 - 7/8	6	60722

WISS AUTO DUTY UTILITY SHEARS



No. 2-DA

Florist and dental shears. Solid steel. Hot drop-forged. Serrated. Nickel plated blades. Black handles.

Overall Length (inches)	Length of cut (inches)	Weight (onzes)	UPC No.
8	2 - 1/2	9	60762



OSBORNE E-Z CUT LEATHER SHEARS



No. 708

At last a shear that cuts soft leather up to 8-oz. as easily as butter. Try them- compare them- you will be amazed. Knife-edge, ultra sharp blades are chromed-plated, blunt points.

Length (inches)	Length of cut (inches)	Weight ea (oz)	UPC No.
8 1/4	3	7	60692

WISS LEATHER OR BELT SHEARS



No. 8BLT

Specially designed for cutting heavy leather or tough materials. One blade serrated to prevent slipping. Heavy construction, powerful leverage. Straight handles, enameled black. Polished blades.

Length (inches)	Length of cut (inches)	Weight ea (oz)	UPC No.
8 5/8	3 1/8	12	60708

WISS QUICK-CLIP SPEED CUTTERS



No. 1570-QC

Stainless steel replaceable blades. Positive spring action reopens blades for fast cutting. Heavy duty contour designed frames. Ideal for thread cutting, seam ripping, garment finishing, flower spring, etc. With sharp points.

Replacement blades part No. 1570-K UPC No. 10786

Overall Length (inches)	Length of cut (inches)	Weight (onzes)	UPC No.
4 - 3/4	1 - 1/4	2	10782

WISS THREAD CLIPS



No. TC-1

Ideal for clipping threads, strings and ripping seams. Positive action, self-opening spring provides fast, clean cutting. Hot drop-forged of fine cutlery steel. Regular edge. Sharp points. Nickel plated. Comes with a red plastic safety protection to prevent damage in the points.

Overall Length (inches)	Length of cut (inches)	Weight (onzes)	UPC No.
4 - 5/8	1	2 - 1/2	60772

WISS THREAD CLIPS



No. TC-5

Similar to above Thread Clips No. 1570-QC but it has blunt points to prevent damage on the thread.

Overall Length (inches)	Length of cut (inches)	Weight (onzes)	UPC No.
4 - 5/8	1	2 - 1/2	60776



WISS METAL MASTER SNIPS

Compound action snips cut with half the effort required with standard types. They may be used on all metals for which any other hand snips are suitable. Colorful vinyl grips which prevent slipping and offer positive model identification.

No.M1R	No.M2R	No.M3R	No.M5R	No.M6R	No.M7R	No.M300
(Cuts Left)	(Cuts Right)	(Cuts Comb. and Straight)	(Bulldog Comb.)	(Cuts Right)	(Cuts Right)	(Cuts long Comb.)

No.	Color Grips	Overall Length (inches)	Length of cut(inches)	Weight (onzes)	UPC No.
M1R	Red	9 - 3/4	1 - 3/8	12	65198
M2R	Green	9 - 3/4	1 - 3/8	12	10754
M3R	Yellow	9 - 3/4	1 - 1/2	12	10756
M5R	Red	9 - 1/4	7/8	12	10758
M6R	Red	9 - 1/4	7/8	12	65204
M7R	Red	9 - 1/4	7/8	12	65206
M300	Yellow	9 - 1/4	7/8	12	10755

WISS STRAIGHT BLADES METAL SNIPS



No. J-7S

Hot drop-forged and fully nickel plated with black enameled handles. Used for Electronic, Aircraft and Missile mfg., and by Jewelers and Dental Technicians.

Overall Length (inches)	Length of cut(inches)	Weight (onzes)	UPC No.
7	1 - 1/4	4	60744



The punches below are forge from the finest quality high carbon steel. Hardened and tempered points for industrial use. Pointed ends are highly polished. Hexagon shanks in black industrial finish.

CENTER PUNCHES

Osborne No. 353



Hex stock size (inches)	Length (inches)	Weight ea (oz)	UPC No.
1/4	4 1/2	1	52310
3/8	4 1/2	2	52312
1/2	6	5	52314
5/8	6 1/2	8	52316

PRICK PUNCHES

Osborne No. 354

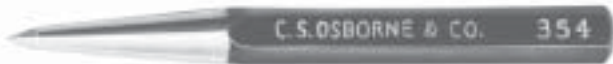

Hex stock size (inches)	Length (inches)	Weight ea (oz)	UPC No.
1/4	4 1/2	1	52330
5/16	4 1/2	2	52332
3/8	5	5	52334
1/2	6	8	52336
5/8	6 1/2	8	52338

SOLID PUNCHES

Osborne No. 355

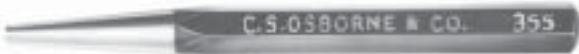

Point diameter (inches)	Hex stock size (inches)	Length (inches)	Weight ea (oz)	UPC No.
1/8	5/16	4 1/2	2	52400
1/4	5/8	6 1/2	8	52404
3/16	3/8	5	2	52402
5/16	3/4	7	12	52406
3/8	7/8	8	19	52408

PIN PUNCHES

Osborne No. 357



Point diameter (inches)	Hex stock size (inches)	Length (inches)	Weight ea (oz)	UPC No.
3/32	1/4	4 - 1/2	1	52370
1/8	3/8	6	2	52372
5/32	3/8	6	2	52374
3/16 x 3/8	3/8	6	2	52376
7/32	3/8	6	2	52380
3/16 x 1/2	1/2	6	4	52378
1/4	1/2	6	4	52382
5/16	1/2	9	6	52384

ALIGNING PUNCHES

Osborne No. 359



Point diameter (inches)	Hex stock size (inches)	Length (inches)	Weight ea (lbs) (oz)	UPC No.
1/4	1/2	10	- 8	52350
5/16	5/8	12	- 15	52356
5/16	3/4	12	1 4	52354
3/8	7/8	15	2 1	52352



CUTTING PAD



Osborne No. 603

Made of a special formula resilient vinyl plastic, these tough cutting pads are ideal for use with Osborne Punches. They are long wearing and can be used on both sides. Cutting pads should be used on a solid base for best results.

Other sizes quoted upon application.

Size (inches)	Weight ea (lbs) (oz)	UPC No.
10 x 10 x 1/2	2 4	67692

SPLIT HEAD HAMMER

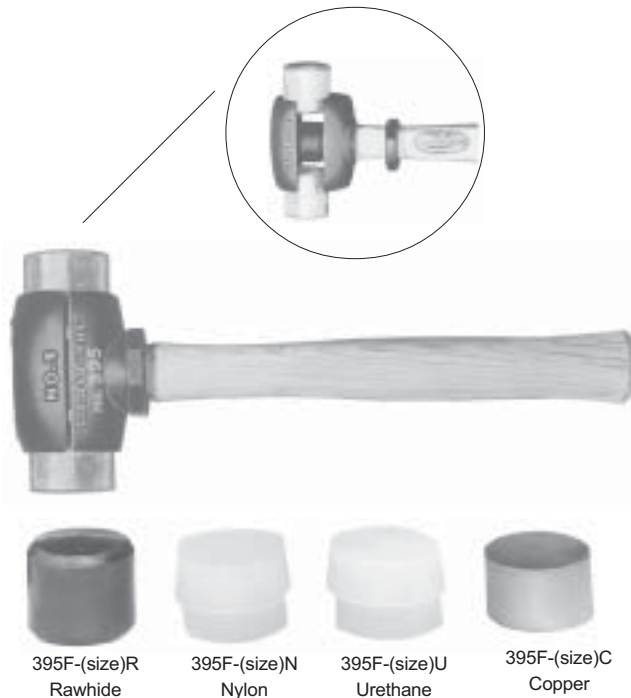

Osborne No. 395

Ideal for use with punches, grommet dies and wherever a cushioned blow is desired. No trouble to replace faces. Just loosen the safety nut, remove the worn face, insert replacement and tighten. Long wearing. Rawhide, nylon, urethane and copper faces available. Rawhide faces supplied if none is specified.

Osborne No.	Description	Weight pair (lbs) (oz)	Diameter of face (inches)	Length of head (inches)	UPC No.
395-1R	Sz. 1 - Rawhide	1 9	1 1/4	3 5/8	11090
395-2R	Sz. 2 - Rawhide	2 -	1 1/2	4 1/4	11094
395-3R	Sz. 3 - Rawhide	2 15	1 3/4	4 7/8	11098
395-1N	Sz. 1 - Nylon	1 8	1 1/4	3 5/8	11092
395-2N	Sz. 2 - Nylon	2 -	1 1/2	4 1/4	11096
395-3N	Sz. 3 - Nylon	2 15	1 3/4	4 7/8	11100
395-1U	Sz. 1 - Urethane	1 8	1 1/4	3 5/8	11091
395-2U	Sz. 2 - Urethane	2 -	1 1/2	4 1/4	11095
395-3U	Sz. 3 - Urethane	2 15	1 3/4	4 7/8	11099
395-1C	Sz. 1 - Copper	2 -	1 1/4	3 5/8	11093
395-2C	Sz. 2 - Copper	2 15	1 1/2	4 1/4	11097
395-3C	Sz. 3 - Copper	4 4	1 3/4	4 7/8	11101

REPLACEMENT FACES

Osborne No.	UPC No.	Osborne No.	UPC No.	Osborne No.	UPC No.	Osborne No.	UPC No.	Osborne No.	UPC No.	Osborne No.	UPC No.
395F-1R	11103	395F-3R	11111	395F-2N	11109	395F-1U	11104	395F-3U	11112	395F-2C	11110
395F-2R	11107	395F-1N	11105	395F-3N	11113	395F-2U	11108	395F-1C	11106	395F-3C	11114

RAWHIDE Mallet - with solid head



Osborne No. 196

The head of this lightweight mallet is made entirely of rolled water buffalo rawhide. Handle is white hickory. It is recommended for many jobs where the user wishes to avoid scarring.

Size No.	Length of head (inches)	Diameter of face (inches)	Length of handle(in)	Weight each (oz)	UPC No.
0	2 3/8	1	9	2	11052
1	3 1/8	1 1/4	9	4	11054
2	3 1/4	1 1/2	9 1/4	6	11056
3	3 3/8	1 3/4	10 1/4	8	11058
4	3 1/2	2	10 1/4	10	11060
5	4	2 1/2	11 1/4	16	11062
6	4 1/2	2 3/4	11 1/4	20	11064



BARREL SHAPED HICKORY MALLET



Osborne No. 89.5

Made of hickory, a carefully finished, well balanced, heavy mallet. Lacquered.

Size No.	Diameter of face (inches)	Diameter of head (inches)	Length of handle (inches)	Weight ea (oz)	UPC No.
2 1/2	2 3/8	5 1/2	10 1/2	16	61014
3	2 1/4	5 1/2	10 1/4	12	61016
3 1/2	2	5 1/4	10 1/4	12	61018
4	1 3/4	5	10 1/4	8	61020

HICKORY MALLET



Osborne No. 90

A serviceable and sturdy mallet, widely used for a variety of purposes. All hickory, lacquered.

Size No.	Diameter of face (inches)	Diameter of head (inches)	Length of handle (inches)	Weight ea (oz)	UPC No.
2	2 3/4	5 1/2	10 1/2	18	61032
3	2 1/2	5 1/2	10 1/2	17	61034
4	2 1/4	5	10 1/2	14	61036
5	2	4	9	8	61038

BLACK RUBBER MALLET



Osborne No. 197

Rubber mallets can be used without fear of marring metal parts. Limited bounce. Head of solid dense black rubber with white hardwood handle.

Size No.	Diameter of face (inches)	Length of head (inches)	Overall length (inches)	Weight ea (oz)	UPC No.
2	2	3 1/4	12	11	61162
3	2 1/2	4 1/2	14	24	61164

WHITE RUBBER MALLET



Osborne No. 396

No. 396 extra heavy white rubber mallet will not mar surface. Superior quality. Finest on the market. Limited bounce. White hardwood handle. Handles only are also sold separately.

Size No.	Diameter of face (inches)	Length of head (inches)	Overall length (inches)	Weight ea (oz)	UPC No.
2	2	3 1/4	12	13	61142
3	2 1/2	4 1/2	14	28	61146



These punches should be used on a wood or plastic cutting block or the Osborne No. #603 Cutting pad. The use of a wooden or rawhide mallet is recommended. Steel hammers are not recommended.

ARCH PUNCH - Original and correctly designed for cutting

Osborne No. 149



Osborne arch punches are drop forged in one piece from the finest special carbon steel in sizes from 3/16". Larger sizes are made with our properly engineered two piece welded construction. A unique feature of the Osborne arch punch is the inside taper which permits the punching to clear easily through the barrel. Punches have fully polished barrel and black enamel handle.

Meets Government Standards

The cutting edge is fully hardened all the way through and properly finished to provide long use trouble free punching. There is no other Hollow Punch that can compare.

Stock sizes shown below in inches with black enamel finish.

Diameter (inches)	Weight ea (lbs) (oz)	UPC No.	Diameter (inches)	Weight ea (lbs) (oz)	UPC No.	Diameter (inches)	Weight ea (lbs) (oz)	UPC No.	Diameter (inches)	Weight ea (lbs) (oz)	UPC No.	Diameter (inches)	Weight ea (lbs) (oz)	UPC No.
3/16	- 2	01010	1 9/16	1 12	01054	2 15/16	1 12	01098	4 5/16	5 -	01142	5 11/16	5 14	01173
1/4	- 2	01012	1 5/8	1 9	01056	3	2 7	01100	4 3/8	5 1	01144	5 3/4	5 14	01174
5/16	- 2	01014	1 11/16	1 9	01058	3 1/16	2 1	01102	4 7/16	5 1	01146	5 13/16	5 15	01175
3/8	- 3	01016	1 3/4	2 4	01060	3 1/8	2 9	01104	4 1/2	5 1	01148	5 7/8	5 15	01176
7/16	- 4	01018	1 13/16	2 1	01062	3 3/16	3 -	01106	4 9/16	5 2	01150	5 15/16	6 -	01177
1/2	- 6	01020	1 7/8	2 5	01064	3 1/4	2 10	01108	4 5/8	5 4	01152	6	6 -	01178
9/16	- 6	01022	1 15/16	1 14	01066	3 5/16	3 -	01110	4 11/16	5 4	01154	6 1/16	6 -	01179
5/8	- 9	01024	2	3 7	01068	3 3/8	4 10	01112	4 3/4	5 5	01156	6 1/8	6 1	01185
11/16	- 8	01026	2 1/16	3 6	01070	3 7/16	4 3	01114	4 13/16	5 6	01158	6 3/16	6 1	01186
3/4	- 9	01028	2 1/8	3 6	01072	3 1/2	4 7	01116	4 7/8	5 6	01160	6 1/4	6 2	01187
13/16	- 8	01030	2 3/16	1 12	01074	3 9/16	2 4	01118	4 15/16	5 7	01161	6 5/16	6 2	01188
7/8	1 1	01032	2 1/4	1 10	01076	3 5/8	3 13	01120	5	5 8	01162	6 3/8	6 3	01189
15/16	- 11	01034	2 5/16	1 13	01078	3 11/16	3 12	01122	5 1/16	5 8	01163	6 7/16	6 3	01190
1	1 1	01036	2 3/8	2 -	01080	3 3/4	4 6	01124	5 1/8	5 10	01164	6 1/2	6 3	01191
1 1/16	1 1	01038	2 7/16	2 2	01082	3 13/16	3 12	01126	5 3/16	5 10	01165	6 9/16	6 4	01192
1 1/8	1 4	01040	2 1/4	1 10	01084	3 7/8	4 2	01128	5 1/4	4 14	01166	6 5/8	6 4	01193
1 3/16	1 2	01042	2 9/16	2 1	01086	3 15/16	3 12	01130	5 5/16	5 11	01167	6 11/16	6 4	01194
1 1/4	1 3	01044	2 5/8	2 4	01088	4	4 12	01132	5 3/8	5 12	01168	6 3/4	6 5	01195
1 5/16	1 2	01046	2 11/16	2 2	01090	4 1/16	4 5	01134	5 7/16	5 12	01169	6 13/16	6 5	01196
1 3/8	1 5	01048	2 3/4	2 8	01092	4 1/8	3 14	01136	5 1/2	5 13	01170	6 7/8	6 5	01197
1 7/16	1 5	01050	2 13/16	2 8	01094	4 3/16	4 6	01138	5 9/16	5 13	01171	6 15/16	6 6	01198
1 1/2	1 12	0105	2 7/8	2 6	01096	4 1/4	5 -	01140	5 5/8	5 14	01172	7	6 6	01199

Stock sizes shown below in millimeters with green enamel finish.

Diameter (mm)	Weight ea (lbs) (oz)	UPC No.	Diameter (mm)	Weight ea (lbs) (oz)	UPC No.	Diameter (mm)	Weight ea (lbs) (oz)	UPC No.	Diameter (mm)	Weight ea (lbs) (oz)	UPC No.	Diameter (mm)	Weight ea (lbs) (oz)	UPC No.
4	- 3	01208	14	- 6	01228	24	1 -	01248	34	1 6	01268	44	3 -	01288
5	- 3	01210	15	- 8	01230	25	1 -	01250	35	1 8	01270	45	3 -	01290
6	- 3	01212	16	- 8	01232	26	1 -	01252	36	1 10	01272	46	3 -	01292
7	- 3	01214	17	- 9	01234	27	1 -	01254	37	1 8	01274	47	3 8	01294
8	- 3	01216	18	- 9	01236	28	1 2	01256	38	2 -	01276	48	3 8	01296
9	- 5	01218	19	- 11	01238	29	1 2	01258	39	2 -	01278	49	3 12	01298
10	- 5	01220	20	- 10	01240	30	1 2	01260	40	1 13	01280	50	3 12	01300
11	- 5	01222	21	- 12	01242	31	1 6	01262	41	2 12	01282	51	4 -	01302
12	- 5	01224	22	- 12	01244	32	1 4	01264	42	2 12	01284	52	4 -	01304
13	- 6	01226	23	- 12	01246	33	1 6	01266	43	3 -	01286			



These punches should be used on a wood or plastic cutting block or the Osborne No. #603 Cutting pad. The use of a wooden or rawhide mallet is recommended. Steel hammers are not recommended.

ARCH PUNCH SETS



Osborne No. K-14

This set of seven arch punches includes the sizes most widely used. They are put up in a sturdy, easy to use canvas tool roll as shown.

1 each of following sizes Osborne No. 149 - Arch Punch:									Weight per set (lbs)	UPC No.
K-14	Sizes (inches)	1/4	3/8	1/2	5/8	3/4	7/8	1	4	01180

Osborne No. K-14MM

This set of seven arch punches includes the most popular millimeter sizes. They are put up in a sturdy, easy to use canvas tool roll as shown.

1 each of following sizes Osborne No. 149 - Arch Punch:									Weight per set (lbs)	UPC No.
K-14MM	Sizes (mm)	6	8	10	12	16	20	25	2 1/2	01179

Osborne No. K-16

This set of seven arch punches of sixteenth sizes are incremented by 1/8" starting with 3/16". They are put up in a sturdy, easy to use canvas tool roll as shown.

1 each of following sizes Osborne No. 149 - Arch Punch:									Weight per set (lbs)	UPC No.
K-16	Sizes (inches)	3/16	5/16	7/16	9/16	11/16	13/16	15/16	4	01181

ARCH PUNCH & TOOL SET



Osborne No. K-17

Set of seven popular tools in a sturdy canvas tool roll.

1 each of the following items:			
Osborne No.	Description	Weight per set (lbs)	UPC No.
149 1/4	Arch punch	4	18172
149 3/8	Arch punch		
149 1/2	Arch punch		
149 5/8	Arch punch		
149 3/4	Arch punch		
4-1	2 1/2" Scratch awl		
V-13	7" Snips		

BELT PUNCH SET



Osborne No. K-245

Kit contains the most frequently used sizes.

1 each of following sizes Osborne No. 245 - Belt Punches						
Sizes	2	4	6	9	12	14
Diameter (inches)	1/8	5/32	3/16	1/4	5/16	3/8
Weight per set (oz)	13					
UPC No.	01520					



These punches should be used on a wood or plastic cutting block or the Osborne No. #603 Cutting pad. The use of a wooden or rawhide mallet is recommended. Steel hammers are not recommended.

MINI-PUNCH SET



Osborne No. K-157

A special punch set for cutting small, precise holes in soft materials where throated or plier punches won't reach. Set has a round handle with slot inside to clear punching. Handle is threaded to accommodate the seven replaceable screw tubes sizes which are shown below. See page 4 at bottom for actual sizes of cutting tubes. Set consists of seven tubes and handle.

Tube size No.	0	1	2	3	4	5	6	Weight per set (oz)	UPC No.
Tube size (inches)	5/64	3/32	7/64	1/8	5/32	11/64	3/16	8	01860

SELF-CENTERING PUNCH SET



Osborne No. K-156

This handy and versatile kit contains threaded handle with self-centering pointed plunger. The threaded handle will accommodate nine interchangeable threaded cutting tubes. The punches in this set will cleanly cut leather, rubber, paper, plastics and other soft materials. The self-centering point makes these punches ideal for cutting concentric washers in small quantities by hand. Sizes of punches listed below. All cutting edges properly hardened. The only professional tool like it. Comes in a sturdy plastic box for storage.

Tube sizes (inches)									Weight per set (lbs)	UPC No.
1/4	5/16	3/8	7/16	1/2	5/8	3/4	7/8	1	2 1/4	01870

REPLACEMENT PARTS			
K156-H	Extra handle	K-156T 1/2	Extra tube
K-156T 1/4	Extra tube	K-156T 5/8	Extra tube
K-156T 5/16	Extra tube	K-156T 3/4	Extra tube
K-156T 3/8	Extra tube	K-156T-7/8	Extra tube
K-156T 7/16	Extra tube	K-156T 1	Extra tube

SELF-CENTERING PUNCH SET



Osborne No. K-159

Similar punch set as above item, but in larger sizes.

Tube sizes (inches)				Weight per set (lbs)	UPC No.
1-1/8	1-1/4	1-3/8	1-1/2	4	01850



REVOLVING PUNCH - for professional and industrial use

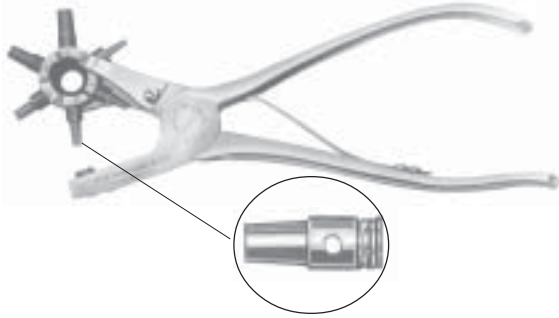

Note: Numbers 155, 153 and 223 tubes are not interchangeable. No. 155 punch take tubes up to size 6 and 7 only as indicated on the cylinder of the punch. Punch tubes measure 3/4" overall.

Size No.	00	0	1	2	3	4	5	6	7
Diameter (inches)	1/16	5/64	3/32	7/64	1/8	5/32	11/64	3/16	13/64

Osborne No. 155

Six tube punch made with tubes 1, 2, 3, 4, 5, 6 or 0, 1, 2, 3, 5 & 7. This punch is known as the best Revolving Punch made. The frame is made of forged steel, highly polished. Cutting tubes are turned from special carbon tool steel and threaded to allow easy replacement. These tubes are individually hardened. The reach or distance from the cutting tube to the back of jaw is 1 1/2". Weight each is 14 oz. Size 0 to 7 provided unless specified otherwise.

Osborne No.	Description	UPC No.
155 1-6	Revolving punch	52010
155 0-7	Revolving punch	52012
155-A	Extra anvil	52052
155-HS	Extra handle spring	02070
155-SP	Extra side spring	02072
155T-(size)	Extra tubes	See below
155T 0-7	Set of replacement tubes	02044
155T 1-6	Set of replacement tubes	02046

REVOLVING PUNCH - Nickel plated



Osborne No. 223

A fine quality pressed frame revolving punch with drive tubes. All tubes are heat treated to give long wear. Furnished with tubes sizes: 0 (5/64"), 1 (3/32"), 2 (7/64"), 3 (1/8") & 6 (3/16"). Packaged on hang up blister packed board 11" x 4". Weighs 6 ounces. Overall length: 8-1/2". UPC No. 02290.

ROUND OR DRIVE PUNCH - Round Shank



Osborne No. 147

Drop forged from finest special carbon steel, carefully hardened, with polished barrel. The hole tapers back from the cutting edge so that the punching clear freely and require only a light blow with a mallet to cut with ease.

Size No.	0	1	2	3	4	5	6	7	8	9	10	11	12	13	14	15	16
Diameter Size	5/64	7/64	1/8	9/64	5/32	11/64	3/16	7/32	1/4	9/32	5/16	3/8	13/32	7/16	15/32	33/64	9/16
Weight ea (oz)	2	2	2	2	2	2	2	3	3	3	3	4	4	6	6	7	9
UPC No.	51410	51412	51414	51416	51418	51420	51422	51424	51426	51428	51430	51432	51434	51436	51438	51440	51442

BELT PUNCH - Round shank



Osborne No. 245

Hardened cutting edge - milled clearing hole. Polished barrel. Widely used in the furniture industry. **Also available in millimeters sizes 2 to 20 mm.**

Size No.	00	0	1	2	3	4	5	6	7	8	9	10	11	12	13	14	15	16	1/2	9/16	5/8
Diameter Size	1/16	5/64	3/32	1/8	9/64	5/32	11/64	3/16	13/64	7/32	1/4	17/64	9/32	5/16	11/32	3/8	13/32	7/16			
Weight ea (oz)	1	1	1	1	1	1	1	1	1	1	1	3	3	3	4	4	4	4	7	9	9
UPC No.	51460	51462	51464	51466	51468	51470	51472	51474	51476	51478	51480	51482	51484	51486	51488	51490	51492	51494	51496	51500	51498

OBLONG CUTTING PUNCH



Osborne No. 400

Polished barrel with hardened cutting edge. Hole tapers inside for easy punching clearings. Properly welded.

Size No.	Size (inches)	Weight ea (oz)	UPC No.
1	11/16 x 3/16	5	01644
2	7/8 x 1/4	6	01646



Osborne grommet inserting dies and grommet hole cutters are numbered to correspond with standard size grommets. The dies are guaranteed to set the proper size and style Osborne grommets. Grommet dies and cutters should be used with a rawhide hammer or wooden mallet, not with a steel hammer. We recommend our #395 rawhide hammers for this purpose.

GROMMET INSERTING DIES



Osborne No. 216

Sets plain rim washers and grommets. Sizes 00 through 5 are made from high grade tool steel, while size 6 and up are malleable iron casting. Properly machined and hardened. The finest industrial grommet die made. For best results use only Osborne grommets and washers.

Size No.	Weight each (lbs)	Weight each (oz)	UPC No.	Size No.	Weight each (lbs)	Weight each (oz)	UPC No.
00	1	6	13212	5	2	10	13224
0	1	6	13214	6	3	15	13226
1	1	7	13216	10	3	10	13232
2	1	7	13218	11	4	15	13234
3	1	9	13220	15	5	15	13236
4	2	8	13222				

Osborne No. 217

Sets spur washers and grommets. Sizes 0 through 5 are made from high grade tool steel while sizes 6, 7 & 8 are malleable iron castings. Made to U.S. Government specifications.

Size No.	Weight each (lbs)	Weight each (oz)	UPC No.	Size No.	Weight each (lbs)	Weight each (oz)	UPC No.
0	1	6	13244	5	2	10	13254
1	1	7	13246	6	3	15	13256
2	1	7	13248	7	4	6	13258
3	1	9	13250	8	5	8	13260
4	2	8	13252				

BRASS PLAIN RIM GROMMETS AND WASHERS



Osborne No. G1

For best results in setting No. G1 grommets and washers use an Osborne No. 500 hole punch and an Osborne No. 216 setting die with corresponding sizes.

Size No.	Diameter of hole when set (inches)	Weight per gross (lbs)	Weight per gross (oz)	UPC No.
00	3/16	-	2	13012
0	1/4	-	5	13014
1	9/32	-	8	13016
2	3/8	-	12	13018
3	7/16	1	2	13020
4	1/2	1	8	13022
5	5/8	1	12	13024
6	13/16	6	-	13026

Osborne No. N1

Same specification as above except **NICKEL PLATED**

BRASS ROLLED RIM GROMMETS AND SPUR WASHERS



Osborne No. G2

For best results in setting No. G2 spur washers and grommets use an Osborne No. 500 hole punch and an Osborne No. 217 setting die.

Size No.	Diameter of hole when set (inches)	Weight per gross (lbs)	Weight per gross (oz)	UPC No.
0	1/4	-	13	13044
1	5/16	1	2	13046
2	3/8	1	10	13048
3	7/16	2	4	13050
4	9/16	2	4	13052
5	5/8	3	8	13054
6	3/4	5	10	13056
7	15/16	5	10	13058
8	1 1/16	8	2	13060

Osborne No. N2

Same specification as above except **NICKEL PLATED**

GROMMET HOLE CUTTER

Hole cutter	Hole size	Weight ea (oz)	UPC No.	Hole cutter	Hole size	Weight ea (oz)	UPC No.
00A	3/16	2	51610	4A	1/2	6	51620
0A	1/4	2	51612	5A	5/8	9	51622
1A	9/32	3	51614	6A	3/4	9	51624
2A	3/8	3	51616	7A	7/8	12	51626
3A	7/16	6	51618	8A	1	13	51628

Osborne No. 500

Drop forged, hardened and polished edge. Inside tapered for easy clearance. Use with corresponding grommets and setting dies.





MIDGET GROMMET DIE



Osborne No. 235

For setting plain rim washers and grommets. This die is designed for use where only a few grommets are to be inserted.

Size No.	Weight ea (lbs)	UPC No.	Size No.	Weight ea (lbs)	UPC No.
0	1	13274	3	1 1/4	13280
1	1	13276	4	1 1/4	13281
2	1 1/4	13278			

GROMMETS



Osborne No. G1S

Packed 2 dozen brass plain rim grommets and plain washers in a hang up bag. Refills for K234. Cards and baggies measure approximately 4" x 5 1/2".

Size No.	Weight ea (oz)	UPC No.	Size No.	Weight ea (oz)	UPC No.
0	1	13000	3	2 1/2	13003
1	1 1/2	13001	4	4	13004
2	1 1/2	13002			

Osborne No. N1S

Packed 2 dozen nickel plain rim grommets and plain washers in a hang up bag. Refills for K234. Cards and baggies measure approximately 4" x 5 1/2".

Size No.	Weight ea (oz)	UPC No.	Size No.	Weight ea (oz)	UPC No.
0	1	13005	3	2 1/2	13008
1	1 1/2	13006	4	4	13009
2	1 1/2	13007			

GROMMET KIT

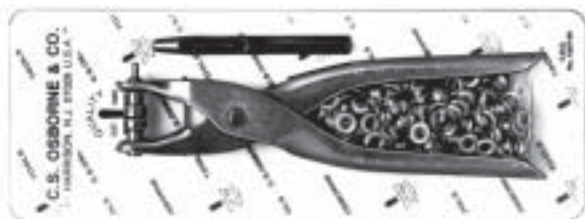

Osborne No. K257-00

Kit includes No. 257 Grommet Setting Pliers, No. 245 Hole Punch and gross of No. G1-00 Grommets and Washers. Diameter of hole when set 3/16". Card measures: 11" x 4".

Weight ea (oz)	UPC No.
11	13292



SET-IT YOURSELF GROMMET KIT



Osborne No. K-234

Hang up card in an easy to use display box. Complete instructions on back of each card. For Do-It-Yourself Home Repair. Kit has grommet die, punch, cutting board and grommets. Sizes zero and one, four dozen of grommets; sizes two, three and four have two dozen of grommets. Cards measure 10-1/2 x 5".

Size No.	Weight ea (oz)	Grommets in ea.	UPC No.
0	14 oz.	4 dozen	13320
1	15 oz.	4 dozen	13322
2	17 oz.	2 dozen	13324
3	18 oz.	2 dozen	13326
4	19 oz.	2 dozen	13328

HOME GROMMET INERTING KIT



Osborne No. K235

A complete and inexpensive kit for consumer use. Each kit consists of a No. 235 grommet die, a No. 245 cutting punch, three dozen brass plain rim grommets and washers, a small cutting board and complete instructions. Packed in a caseboard box.

Size No.	Diameter of grommets (inches)	Weight per kit (lbs)	UPC No.
0	1/4	1 1/4	13294
1	9/32	1 1/2	13296
2	3/8	1 3/4	13298
3	7/16	1 3/4	13300
4	1/2	1 3/4	13302



①



②



③

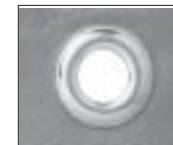

④



RIVETS / SETTERS

Osborne No. 1700

Copper rivets and burrs. Use with Osborne Nos. 169 & 170.
Packed 1 lb. per box.



No. 170

Choose the setter with a hole diameter slightly larger than the rivet being set. Sizes for #170 correspond with popular 8, 9 and 10 copper rivets. For other size rivets, use table below to determine proper size of #169 Rivet Setter. Push the rivet through the hole then turn the material over. Place burr on rivet, then use the rivet setting tool's straight hole to drive the burr down tight against the material. Cut the rivet off close to the burr with side or end nippers. Do not cut off flush with the burr, but leave about 1/16 of an inch above the burr. The hole on the side of the rivet setter can be used to dislodge any waste that is wedged into the tool. Place the concave recess of setter on the burr. Hold perpendicular and strike the tool forcefully, turning to the left then right as you strike. This spreads the end of the rivet over the burr, simultaneously rounding its end. A few extra blows from the soft faced mallet can be used to flatten the rivet end a bit, if desired.



No. 169

Polished face, black finish, forged steel. Hardened working end.

Osborne No.	Hole Dia.	Copper Rivet	Rivet Shank Dia.	Weight ea (oz)	UPC No.
169-1	.234	6	.228	9	67226
169-2	.213	7	.191	9	67228
169-6	.141	12	.137	5	67236

Osborne No.	Hole Dia.	Copper Rivet	Rivet Shank Dia.	Weight ea (oz)	UPC No.
170-8	.191	8	.181	5	67252
170-9	.171	9	.161	5	67254
170-10	.161	10	.151	5	67256

Size or Number	6	7	8	9	10	12	13	14
Diameter under head (in)	.228	.191	.181	.161	.151	.137	.118	.102
Length overall (in)	3/4	3/4	3/4	3/4	3/4	3/4	3/4	3/4
Number of rivets & burrs per lb.	50	75	90	115	135	170	210	300
Tool to be used	169-1	169-2	170-8	170-9	170-10	169-6	169-7	169-8
UPC No.	67276	67277	67278	67279	67280	67282	67283	67284

Osborne No. 170

Drop forged, polished face.

Osborne No.	Hole Dia.	Copper Rivet	Rivet Shank Dia.	Weight ea (oz)	UPC No.
170-8	.191	8	.181	5	67252
170-9	.171	9	.161	5	67254
170-10	.161	10	.151	5	67256

Osborne No. 169

Polished face, black finish, forged steel. Hardened working end.

Osborne No.	Hole Dia.	Copper Rivet	Rivet Shank Dia.	Weight ea (oz)	UPC No.
169-1	.234	6	.228	9	67226
169-2	.213	7	.191	9	67228
169-6	.141	12	.137	5	67236

RIVET SETTER



Osborne No. 443

For use with loose leaf binders. Overall length 4". Shank diameter is 3/8". Weighs 2 ounces. UPC No. 67352.

RIVET SETTER



Osborne No. 168

Rivet setter with concave end and knurled handle.

Overall length (inches)	Shank diameter (inches)	Weight ea (oz)	UPC No.
3 7/8	3/8	2	67220

EYELET SETTER

No. 456



No. 24-24



Osborne No. 456 & 24-24

Spreads eyelets so that they can be flattened with a mallet or rawhide hammer. Knurled handle prevents slipping. Nickel plated.

Osborne No.	Overall length (inches)	Shank diameter (inches)	Weight ea (oz)	UPC No.
456	4 3/8	5/16	1	67402
24-24	4 3/8	1/4	1	67400

RIVET SETTER



Osborne No. 257

Enables eyelets to be set in a paper card without preparation. Pierces material and sets 5/32" and 7/32" in a single preparation. Please specify size when ordering. Weighs 7 ounces.



SNAP SET KIT



Osborne No. K229-20 (Baby Snaps)

Osborne No. K229-24 (Standard Snaps)

Includes parts to complete six 5/8" standard nickel plated brass snaps or 1/2" baby snaps along with flaring tool and die. Comes with instructions on back of hang up card 4 3/4" x 5-3/4".

Osborne No.	Weight ea (oz)	UPC No.
K229-20	3	14230
K229-24	3	14232

SNAP SETTER - With snaps



Osborne No. K-230

An easy to use hand snap set. Snaps are nickel plated brass. Set comes with 25 complete standard 5/8" size 24 snaps, flaring tool and two dies (concave and stud).

Osborne No.	Weight ea (oz)	UPC No.
K-230	11	14228

SNAP SETTER ONLY



Osborne No. 230-SET

Settler only, no snaps included

Osborne No.	Weight ea (oz)	UPC No.
230-SET	7	14236

DURABLE SNAP SETTER



Osborne No. 229

Osborne No. 229-20 - Setting die for #20 Baby Dot snaps.

Osborne No. 229-24 - Setting die for #24 Standard snaps.

Comes with flaring tool and a double-sided die.

Size No.	Weight ea (oz)	UPC No.
20	1	17282
24	2	17284



SNAPS FASTENERS

Available in Brass and Steel with three finishes: Nickel, Cooper Black and Shiny Brass. Interchangeable with durable fasteners. To be set without snaps dies. **We have two sizes of snaps which are: # 20 = 1/2" Baby Snap and # 24 = 5/8" Standard Snap.**

**DESCRIPTIONS: C = 100 PIECES PER BOX
M = 1000 PIECES PER BOX**



CAP



SOCKET



STUD



EYELET

KITS (4 PCS.)

OSBORNE No.	DESCRIPTION	UPC No.
K-2708-11-C	#20 BRASS 4-PC. SNAPS/NICKEL100/PK	14200
K-2708-11-M	#20 BRASS 4-PC. SNAPS/NICKEL1000/PK	14202
K-2713-16-C	#20 BRASS 4-PC. SNAPS/COPPER BLACK 100/PK	14204
K-2713-16-M	#20 BRASS 4-PC. SNAPS/COPPER BLACK1000/PK	14206
K-2717-20-C	#20 BRASS 4-PC. SNAPS/ SHINY BRASS 100/PK	14208
K-2717-20-M	#20 BRASS 4-PC. SNAPS/SHINY BRASS 1000/PK	14210
K-3708-11-C	#20 STEEL 4-PC. SNAPS/NICKEL 100/PK	14212
K-3708-11-M	#20 STEEL 4-PC. SNAPS/NICKEL 1000/PK	14214
K-3713-16-C	#20 STEEL 4-PC. SNAPS/COPER BLACK 100/PK	14216
K-3713-16-M	#20 STEEL 4-PC. SNAPS/COPPER BLACK 1000/PK	14218
K-3717-20-C	#20 STEEL 4-PC. SNAPS/SHINY BRASS 100/PK	14220
K-3717-20-M	#20 STEEL 4-PC. SNAPS/SHINY BRASS 1000/PK	14222
K-4708-11-C	#24 BRASS 4-PC. SNAPS/NICKEL 100/PK	14235
K-4708-11-M	#24 BRASS 4-PC. SNAPS/NICKEL 1000/PK	14237
K-4713-16-C	#24 BRASS 4-PC. COPPER BLACK 100/PK	14238
K-4713-16-M	#24 BRASS 4-PC. COPPER BLACK1000/PK	14239
K-4717-20-C	#24 BRASS 4-PC. SHINY BRASS 100/PK	14240
K-4717-20-M	#24 BRASS 4-PC. SHINY BRASS 1000/PK	14241
K-5708-11-C	#24 STEEL 4-PC. SNAPS/NICKEL 100/PK	14245
K-5708-11-M	#24 STEEL 4-PC. SNAPS/NICKEL 1000/PK	14247
K-5713-16-C	#24 STEEL 4-PC. COPPER BLACK 100/PK	14248
K-5713-16-M	#24 STEEL 4-PC. COPPER BLACK 1000/PK	14249
K-5717-20-C	#24 STEEL 4-PC. SHINY BRASS100/PK	14250
K-5717-20-M	#24 STEEL 4-PC. SHINY BRASS 1000/PK	14251

INDIVIDUAL

OSBORNE No.	DESCRIPTION	UPC No.
2708-C	# 20 Brass Eyelet/Nickel C/PK	40002
2708-M	# 20 Brass Eyelet/Nickel M/PK	40004
2709-C	# 20 Brass Cap/Nickel C/PK	40008
2709-M	# 20 Brass Cap/Nickel M/PK	40010
2710-C	# 20 Brass Socket/Nickel C/PK	40014
2710-M	# 20 Brass Socket/Nickel M/PK	40016
2711-C	# 20 Brass Stud/Nickel C/PK	40020
2711-M	# 20 Brass Stud/Nickel M/PK	40022
2713-C	# 20 Brass Eyelet/Copper Black C/PK	40026
2713-M	# 20 Brass Eyelet/Copper Black M/PK	40028
2714-C	# 20 Brass Cap/Copper Black C/PK	40032
2714-M	# 20 Brass Cap/Copper Black M/PK	40034
2715-C	# 20 Socket/Copper Black C/PK	40038
2715-M	# 20 Socket/Copper Black M/PK	40040
2716-C	# 20 Brass Stud/Copper Black C/PK	40044
2716-M	# 20 Brass Stud/Copper Black M/PK	40046
2717-C	# 20 Brass Eyelet/Shiny Brass C/PK	40050
2717-M	# 20 Brass Eyelet/Shiny Brass M/PK	40052
2718-C	# 20 Brass Cap/Shiny Brass C/PK	40056
2718-M	# 20 Brass Cap/Shiny Brass M/PK	40058
2719-C	# 20 Brass Socket/Shiny Brass C/PK	40062
2719-M	# 20 Brass Socket/Shiny Brass M/PK	40064
3708-C	# 20 Steel Eyelet/Nickel C/PK	40074
3708-M	# 20 Steel Eyelet/Nickel M/PK	40076
3709-C	# 20 Steel Cap/Nickel C/PK	40080



SNAPS FASTENERS

DESCRIPTIONS: C = 100 PIECES PER BOX
M = 1000 PIECES PER BOX

OSBORNE No.	DESCRIPTION	UPC No.
3709-M	# 20 Steel Cap/Nickel M/PK	40082
3710-C	# 20 Steel Socket/Nickel C/PK	40086
3710-M	# 20 Steel Socket/Nickel M/PK	40088
3711-C	# 20 Steel Stud/Nickel C/PK	40092
3711-M	# 20 Steel Stud/Nickel M/PK	40094
3713-C	# 20 Steel Eyelet/Cooper Black C/PK	40098
3713-M	# 20 Steel Eyelet/Cooper Black M/PK	40100
3714-C	# 20 Steel Cap/Copper Black C/PK	40104
3714-M	# 20 Steel Cap/Copper Black M/PK	40106
3715-C	# 20 Steel Socket/Copper Black C/PK	40110
3715-M	# 20 Steel Socket/Copper Black M/PK	40112
3716-C	# 20 Steel Stud/Cooper Black C/PK	40116
3716-M	# 20 Steel Stud/Cooper Black M/PK	40118
3717-C	# 20 Steel Eyelet/Shiny Brass C/PK	40122
3717-M	# 20 Steel Eyelet/Shiny Brass M/PK	40124
3718-C	# 20 Steel Cap/Shiny Brass C/PK	40128
3718-M	# 20 Steel Cap/Shiny Brass M/PK	40130
3719-C	# 20 Steel Socket/Shiny Brass C/PK	40134
3719-M	# 20 Steel Socket/Shiny Brass M/PK	40136
3720-C	# 20 Steel Stud/Shiny Brass C/PK	40140
3720-M	# 20 Steel Stud/Shiny Brass M/PK	40142
4708-C	# 24 Brass Eyelet Nickel C/PK	78368
4708-M	# 24 Brass Eyelet Nickel M/PK	78372
4709-C	# 24 Brass Cap/Nickel C/PK	78380
4709-M	# 24 Brass Cap/Nickel M/PK	78384
4710-C	# 24 Brass Socket/Nickel C/PK	78392
4710-M	# 24 Brass Socket/Nickel M/PK	78396
4711-C	# 24 Brass Stud/Nickel C/PK	78356
4711-M	# 24 Brass Stud/Nickel M/PK	78360
4712-C	Brass Low Bed Stud 100	40146
4712-M	Brass Low Bed Stud 1000	40148
4713-C	# 24 Brass Eyelet/Copper Black C/PK	78428
4713-M	# 24 Brass Eyelet/Copper Black M/PK	78432
4714-C	# 24 Brass Cap/Copper Black C/PK	40152
4714-M	# 24 Brass Cap/Copper Black M/PK	40154
4715-C	# 24 Brass Socket/Copper Black C/PK	40158
4715-M	# 24 Brass Socket/Copper Black M/PK	40159
4716-C	# 24 Brass Stud/Copper Black C/PK	40162
4716-M	# 24 Brass Stud/Copper Black M/PK	40164
4717-C	# 24 Brass Eyelet/Shiny Brass C/PK	40168

OSBORNE No.	DESCRIPTION	UPC No.
4717-M	# 24 Brass Eyelet/Shiny Brass M/PK	40170
4718-C	# 24 Brass Cap/Shiny Brass C/PK	40174
4718-M	# 24 Brass Cap/Shiny Brass M/PK	40176
4719-C	# 24 Brass Socket/Shiny Brass C/PK	40180
4719-M	# 24 Brass Socket/Shiny Brass M/PK	40182
4720-C	# 24 Brass Stud/Shiny Brass C/PK	40186
4720-M	# 24 Brass Stud/Shiny Brass M/PK	40188
4908-C	# 24 Brass Eyelet-XL Nickel C/PK	40198
4908-M	# 24 Brass Eyelet-XL Nickel M/PK	40200
4909-C	# 24 Brass Cap-XL Nickel C/PK	40204
4909-M	# 24 Brass Cap-XL Nickel M/PK	40206
5708-C	# 24 Steel Eyelet/Nickel C/PK	78584
5708-M	# 24 Steel Eyelet/Nickel M/PK	78588
5709-C	# 24 Steel Cap/Nickel C/PK	78596
5709-M	# 24 Steel Cap/Nickel M/PK	75600
5710-C	# 24 Steel Socket/Nickel C/PK	78608
5710-M	# 24 Steel Socket/Nickel M/PK	78612
5711-C	# 24 Steel Stud/Nickel C/PK	78620
5711-M	# 24 Steel Stud/Nickel M/PK	78624
5712-C	# 24 Steel Stud/Low bed C/PK	78632
5712-M	# 24 Steel Stud/Low bed M/PK	78636
5713-C	# 24 Steel Eyelet/Copper Black C/PK	40222
5713-M	# 24 Steel Eyelet/Copper Black M/PK	40224
5714-C	# 24 Steel Black/Copper Black C/PK	40228
5714-M	# 24 Steel Black/Copper Black M/PK	40230
5715-C	# 24 Steel Socket/Copper Black C/PK	40234
5715-M	# 24 Steel Socket/Copper Black M/PK	40236
5716-C	# 24 Steel Stud/Copper Black C/PK	40240
5716-M	# 24 Steel Stud/Copper Black M/PK	40242
5717-C	# 24 Steel Eyelet/Shiny Brass C/PK	40246
5717-M	# 24 Steel Eyelet/Shiny Brass M/PK	40248
5718-C	# 24 Steel Cap/Shiny Brass C/PK	40252
5718-M	# 24 Steel Cap/Shiny Brass M/PK	40254
5719-C	# 24 Steel Socket/Shiny Brass C/PK	40258
5719-M	# 24 Steel Socket/Shiny Brass M/PK	40260
5720-C	# 24 Steel Stud/Shiny Brass C/PK	40264
5720-M	# 24 Steel Stud/Shiny Brass M/PK	40266

SCREW STUD

Brass screw stud. Used on furniture, automobiles, recreational vehicles, manufactured housing, etc. Designed to snap into a snap ring and shell after it's fully assembled. Available in two length sizes: 3/8" and 5/8".



Osborne No.	Description	UPC No.
4712-3/8C	Br. Screw stud 3/8" pk. 100	78404
4712-3/8M	Br. Screw stud 3/8" pk. 1000	78400
4712-5/8C	Br. Screw stud 5/8" pk. 100	78416
4712-5/8M	Br. Screw stud 5/8" pk. 1000	78420



SAIL PALM



Osborne No. 265

A fine quality leather palm with vinyl iron thimble. Riveted joints. Furnished either in right or left hand. Right hand will be furnished unless otherwise specified.

Osborne No.	Description	Weight ea (oz)	UPC No.
265-RH	Sail palm - right hand	3	67322
265-LH	Sail palm - left hand	3	67324

SEWING PALM



Osborne No. 266

A fine quality leather palm with vinyl iron thimble. Riveted joints. Furnished either in right or left hand. Right hand will be furnished unless otherwise specified.

Osborne No.	Description	Weight ea (oz)	UPC No.
266-RH	Sewing palm - right hand	3	67332
266-LH	Sewing palm - left hand	3	67334

OPEN END THIMBLE



Osborne No. 510

Nickel plated brass thimbles. Coarse grate.

USA Size	Size (inches)	Weight ea (oz)	UPC No.
13 (00)	51/64	1	67652
12 (0)	21/32	1	67654
11 (1)	3/4	1	67656
10 (2)	43/64	1	67658
9	11/16	1	67660
7	5/8	1	67662

CLOSED END THIMBLE



Osborne No. 511

Nickel plated brass thimbles. Coarse grate.

USA Size	Size (inches)	Weight ea (oz)	UPC No.
13 (00)	51/64	1	67672
12 (0)	21/32	1	67674
11 (1)	3/4	1	67676
10 (2)	43/64	1	67678
9	11/16	1	67682
7	5/8	1	67680

OSBORNE



REGULATORS/PINS

UPHOLSTERERS' REGULATOR - With eye



Packed 12 regulators per package.

Extra light			Light			Heavy		
Size No.	Gauge	UPC No.	Size No.	Gauge	UPC No.	Size No.	Gauge	UPC No.
6	10	16052	6	9	16032	6	6	16042
8	10	16054	8	9	16034	8	5	16044
10	10	16056	10	8	16036	10	5	16046
			12	7	16038	12	5	16048

Osborne No. 306½

REGULATOR - With plastic handle



Osborne No. 520
Packed 12 regulators per package.

Length (inches)	UPC No.
6	66062
8	66064
10	66066
12	66068

UPHOLSTERERS' PINS



Packed per gross.

Osborne No. 190

Size (inches)	Gauge	UPC No.
2 1/2	16	15930
3	16	15932
3 1/2	16	15934
4	16	15936

Osborne No. 190S

Special packing 3 dz. to a box		
Size (inches)	Gauge	UPC No.
3	16	15942
3 1/2	16	15944

"T" PINS Osborne No. 189

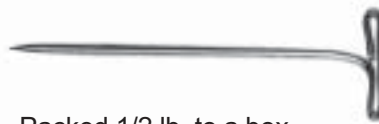

Packed 1/2 lb. to a box.

Osborne No.	Length (inches)	UPC No.
189-20	1 1/4	15912
189-24	1 1/2	15914
189-32	2	15916

TWIST PINS



Packed 100 or 5000 per box.

Osborne No. 199

Length (inches)	Weight per box (oz)	UPC No.
1/2	8	16012

Made of steel. Plastic head. Best quality.

PLASTIC HEAD PINS



Packed 100 per box.

Osborne No. 193

Osborne No.	Color	Length (inches)	Weight per box (oz)	UPC No.
193-B	Blue	2 1/8	4	15962
193-R	Red	2 1/8	4	15964
193-Y	Yellow	2 1/8	4	15966

PUSH PINS



Packed 100 per box.

Osborne No. 183

Length (inches)	Weight per box (oz)	UPC No.
1 - 1/4	6	16022

DRESSMAKERS' PINS

Osborne No. 198



Packed 1 lb. to a box.

Osborne No.	Length (inches)	UPC No.
198-17	1 1/16	15982
198-20	1 1/4	15984
198-24	1 1/2	15986
198-28	1 3/4	15988
198-32	2	15990

GLASS HEAD PINS

Osborne No. 181



Packed 100 per box.

Length (inches)	Weight per box (oz)	UPC No.
1 1/4	1	16020

MONOFILAMENT THREAD

Osborne No. 4705



A clear thread. Blends in with fabric being sewn and is very strong. No.

18 very light thread is for bar tacking, earging, quilting, etc. No 40 is for general upholstery work, canvas, etc. No 52 extra heavy duty thread is for heavy fabric, canvas, etc.

Osborne No.	Aprox. Weight per canisters (lbs)	Breaking Strength (lbs)	UPC No.
4705-18	1 - 1/2	4	78336
4705-40	1 - 1/2	6	78340
4705-52	1 - 1/2	7.4	78352



OSBORNE NEEDLE GAUGES

OSBORNE needles and pins have long been considered a standard for fine quality. Experience and efficiency in the art of needle making for over one hundred and seventy years have produced the dependable tools well known throughout the trade as **OSBORNE NEEDLES AND PINS**.

The uniform quality of these needles and pins is carefully maintained by the consistent efforts of the skillful craftspeople who make them. All are nickel plated. Papers cannot be broken.

Quotation for special needles upon request.

OSBORNE needles are gauged by the Standard Wire Gauge as illustrated opposite. The gauge sizes are also listed in thousandths of an inch and millimeter sizes in thousandths are also shown.

Actual diameter of wire	English gauge	Decimal equiv. (inch)	Decimal equiv. (mm)
	5	.212	5.385
	5 1/2	.202	5.130
	6	.192	4.877
	7	.176	4.470
	7 1/2	.168	4.267
	8	.160	4.064
	9	.144	3.658
	10	.128	3.251
	11	.116	2.946
	11 1/2	.110	2.794
	12	.104	2.642
	13	.092	2.337
	14	.080	2.032
	15	.072	1.829
	16	.064	1.626
	17	.056	1.422
	18	.048	1.219
	19	.040	1.016
	20	.036	0.914
	21	.032	0.813
	22	.028	0.711
	23	.024	0.610

Curved needles are listed in this catalogue according to length (over all) from eye to point. The bottom lines in the following table of measurements also gives the shortest distance (across) from eye to point.

2	2 1/2	3	2	4	5	6	7	8	9	10	inches over all
1 1/2	1 3/4	2	2 3/8	2 3/4	3 3/8	4	4 3/4	5 1/4	6	6 3/4	inches across



Osborne No. K-1



Each kit contains:

- 2 ea. Curved upholstery needles: 2" & 2½"
- 1 ea. Special bent needle for sewing up fowls or wherever sewing with a string is needed.
- 1 ea. Awning or canvas needle - (can be used on sails too).
- 1 ea. Carpet or very heavy material needle.

Weight per kit 8 oz.	UPC No. 15012
----------------------	---------------

Osborne No. K-10



Each kit contains 20 Sewing needles, 10 Darners and 1 Threader

Kits per box	Weight per box (oz)	UPC No.
12	4	15022

Osborne No. K-3



Each card is composed of 4 round point needles in following sizes: 3", 4", 5" & 6".

Kits per box	Weight per box (oz)	UPC No.
12	6	15014

Osborne No. K-4



Each card is composed of 4 diamond point needles in following sizes: 3", 4", 5" & 6".

Kits per box	Weight per box (oz)	UPC No.
12	6	15016



STRAIGHT ROUND POINT NEEDLES

Osborne No. K-5

Each card printed in attractive yellow and blue and is cellophane covered to protect against rust.

1 ea. of following sizes: 6", 8", 10" & 12"

Kits per box	Weight per box (oz)	UPC No.
12	18	15018

Osborne No. K-11



Each kit contains 25 assorted handsewing needles: 10 ea. #7, 10 ea. #5 5 ea. #3.

Kits per box	Weight per box (oz)	UPC No.
12	4	15028

Osborne No. K-12



Each kit contains 5 Chenille & 5 Tapestry needles: 1ea. #18, 2 ea. #20, 2 ea. #22.

Kits per box	Weight per box (oz)	UPC No.
12	4	15034

Osborne No. K-15



Each kit contains 12 assorted Darners sizes 0/5.

Kits per box	Weight per box (oz)	UPC No.
12	4	15040

Osborne No. K-7



Each card is composed of 4 round point extra light needles in following sizes: 2½", 3", 3½" & 4".

Kits per box	Weight per box (oz)	UPC No.
12	4	15020

ALL CARDS ARE PACKED 12 CARDS PER BOX AND BOX CANNOT BE BROKEN



CURVED 3 SQUARE POINT

1 dozen needles per package.



Osborne No. 502X Extra light

Size (in.)	2	2 1/2	3	3 1/2	4
Gauge	21	20	19	18	18
UPC No.	15242	15244	15246	15248	15250

Osborne No. 502 1/2 Light

Size (in.)	2	2 1/2	3	3 1/2	4	5	6	7	8
Gauge	19	18	18	17	17	16	16	15	15
UPC No.	15262	15264	15266	15268	15270	15272	15274	15276	15278

Osborne No. 502 Heavy

Size (in.)	2	2 1/2	3	3 1/2	4	5	6	7	8	10
Gauge	17	17	16	16	15	14	14	14	13	13
UPC No.	15292	15294	15296	15298	15300	15302	15304	15306	15308	15310

CURVED ROUND POINT

1 dozen needles per package.



Osborne No. 513X Cord, extra light

Size (in.)	2	2 1/2
Gauge	23	23
UPC No.	15192	15194

Osborne No. 513 Cord, light

Size (in.)	2	2 1/2
Gauge	19	19
UPC No.	15196	15198

Osborne No. 501X Extra light

Size (in.)	2	2 1/2	3	3 1/2	4
Gauge	21	20	19	18	18
UPC No.	15112	15114	15116	15118	15120

Osborne No. 501 1/2 Light

Size (in.)	2	2 1/2	3	3 1/2	4	5	6	7	8
Gauge	19	18	18	17	16	16	15	15	15
UPC No.	15132	15134	15136	15138	15140	15142	15144	15146	15148

Osborne No. 501 Heavy

Size (in.)	2	2 1/2	3	3 1/2	4	5	6	7	8	10
Gauge	17	17	16	16	15	14	14	14	13	13
UPC No.	15162	15164	15166	15168	15170	15172	15174	15176	15178	15180

CURVED "LEATHER POINT"

1 dozen needles per package. Sharp edges.



Osborne No. 503 Light

Size (in.)	2	2 1/2	3	3 1/2	4	5	6	8
Oval ga.	19	19	16	16	15	15	14	13
Flat ga.	23	23	19	19	19	19	17	17
UPC No.	15322	15324	15326	15328	15330	15332	15334	15336

Osborne No. 553 Heavy

Size (in.)	3	4	5	6	7	8
Oval ga.	15	14	13	13	12	12
Flat ga.	18	17	17	17	14	14
UPC No.	15342	15344	15346	15348	15350	15352

CURVED MATTRESS LONG BAYONET POINT

1 dozen needles per package.



Osborne No. 409

Size (in.)	4	8
Gauge	15	14
UPC No.	15232	15234

LAMPSHADE - ROUND POINT

1 dozen needles per package.



Osborne No. 741

Size (in.)	2	2 1/2	3	3 1/2	4
Gauge	21	21	21	19	19
UPC No.	15212	15214	15216	15218	15220



STRAIGHT SINGLE ROUND POINT 12 needles per package.



Osborne No. 504

Size (in.)	4	5	6	8	10	12	14	16	18
Gauge	15	14	14	14	13	13	13	12	12
UPC No.	15362	15364	15366	15368	15370	15372	15374	15376	15378

Osborne No. 554

Size (in.)	6	8	10	12	14	16	18	BOLSTER NEEDLE 24
Gauge	13	13	12	12	12	11	11	11
UPC No.	15386	15388	15390	15392	15394	15396	15398	15400

STRAIGHT DOUBLE ROUND POINT 12 needles per package.



Osborne No. 505

Size (in.)	6	8	10	12	14	16	18	20
Gauge	14	14	13	13	13	12	12	12
UPC No.	15412	15414	15416	15418	15420	15422	15424	15426

Osborne No. 555

Size (in.)	6	8	10	12	14	16	18
Gauge	13	13	12	12	12	11	11
UPC No.	15432	15434	15436	15438	15440	15442	15444

STRAIGHT SINGLE 3 SQ. POINT
12 needles per package.



Osborne No. 506

Size (in.)	6	8	10	12	14	16	18
Gauge	14	14	13	13	13	12	12
UPC No.	15452	15454	15456	15458	15460	15462	15464

Osborne No. 556

Size (in.)	6	7	8	10	12	14	16	18
Gauge	13	13	13	12	12	12	11	11
UPC No.	15472	15473	15474	15476	15478	15480	15482	15484

FLOCKING NEEDLES



12 needles per package.

Osborne No. 514

Size (in.)	6	7	7	8	8	10
Gauge	12	12	11	12	11	11
UPC No.	15632	15634	15636	15638	15640	15642

STRAIGHT DOUBLE 3 SQ. POINT



12 needles per package.

Osborne No. 507

Size (in.)	6	8	10	12	14	16	18
Gauge	14	14	13	13	13	12	12
UPC No.	15492	15494	15496	15498	15500	15502	15504

Osborne No. 557

Size (in.)	6	8	10	12	14	16	18	20
Gauge	13	13	12	12	12	11	11	11
UPC No.	15512	15514	15516	15518	15520	15522	15524	15526

SAILMAKERS'

25 needles per package.



Osborne No. 509

Size (gauge)	9	10	11	12	13	14	15	16	17
Length (in)	4	3 3/4	3 1/2	3 1/4	3	2 3/4	2 1/2	2 3/8	2 1/4
UPC No.	15612	15614	15616	15618	15620	15622	15624	15626	15628

BENT PACK (2 views)

12 needles per package.



Osborne No. 508

Size (in.)	3	3 1/2	4	5	6	7	8	9	10
Gauge	14	13	12	10	9	7	6	5	4
UPC No.	15552	15554	15556	15558	15560	15562	15564	15566	15568

SPRING EYE STRAIGHT PACK (with cutter) 12 needles per package.



Osborne No. 508-1/2 SE

Size (in.)	4	4 1/2	4	5	5	6	6
Gauge	7	7	8	5	7	5	7
UPC No.	15582	15581	15588	15583	15584	15585	15586



Osborne leather, upholsterer's and hardware needles have long been considered the world standard for fine quality. These needles are manufactured from the finest wire to Osborne exacting quality.

HARNESS NEEDLES - Egg eye



Osborne No. 517

Packed 25 needles per paper.

Size No.	000	00	0	1	2	3	4	5	6	7
Length (in)	2 3/8	2 1/8	2 3/8	2 3/8	2 1/4	2 1/8	1 7/8	1 7/8	1 9/16	1 5/8
Gauge	16	17	18	19	19	20	20	20	21	22
UPC No.	15672	15674	15676	15678	15680	15682	15684	15686	15688	15690

GLOVERS' NEEDLES - Egg eye



Osborne No. 518

Packed 25 needles per paper.

Size No.	000	00	0	1	2	3	4	5	6	7
Length (in)	2 5/16	2 1/16	2	1 7/8	1 13/16	1 11/16	1 5/8	1 9/16	1 7/16	1 3/8
Gauge	17	17	18	18	18	19	19	20	20	22
UPC No.	15712	15714	15716	15718	15720	15722	15724	15726	15728	15730

TAPESTRY NEEDLES - Blunt point Osborne No. 563

Packed 25 needles per paper.

Actual size	Size No.	UPC No.
	13	15842
	14	15844
	16	15846
	18	15848
	20	15850
	22	15852
	24	15854
	26	15856

CHENILLE NEEDLES - Round point Osborne No. 562

Packed 25 needles per paper.

Actual size	Size No.	UPC No.
	13	15768
	14	15770
	16	15772
	18	15774
	20	15776
	22	15778
	24	15780
	26	15782

SMYRNA NEEDLES - Blunt point

Osborne No. 565

Packed 25 needles per paper.

Actual size	Size No.	UPC No.
	1	15872
	3	15874

SMYRNA NEEDLES - Round point

Osborne No. 564

Packed 25 needles per paper.

Actual size	Size No.	UPC No.
		15862
	3	15864

PEARL STRINGING NEEDLES - Sharp point



Osborne No. 560-SP

Packed 25 needles per paper.

Size (mm)	Diameter (mm)	UPC No.
100	0.50	15752
125	0.65	15754
100	0.75	15756

PEARL STRINGING NEEDLES - Blunt point



Osborne No. 560-BP

Packed 25 needles per paper.

Size (mm)	Diameter (mm)	UPC No.
100	0.50	15753
125	0.65	15755
100	0.75	15757



COLLAR NEEDLES - Half moon

Osborne No. 92½

Packed 12 needles per package.



Size overall (inches)	UPC No.
3	15676
5	15878

CARPET NEEDLES - Round point

Osborne No. 515

Packed 25 needles per package.



Size (in.)	1 7/8	2 1/8	2 1/2	3
Gauge	18	17	17	16
UPC No.	15652	15654	15656	15658

CARPET NEEDLES - 3 Square point

Osborne No. 516

Packed 25 needles per package.



Size (inches)	Gauge	UPC No.
2 - 1/2	17	15666

PEARL SEWING NEEDLES

Osborne No. 561

Packed 25 needles per paper.



Size (mm)	Diameter (mm)	UPC No.
30	0.40	15762
40	0.45	15764